

## Contents

<b>1 Extended and Advanced Cascade Controller Option</b>	<b>3</b>
How to read these Operating Instructions	3
High Voltage Warning	3
Safety Instructions	3
Avoid unintended Start	3
Software Version	3
Symbols	4
Safety	4
Caution	5
Introduction to MCO 101 and 102	5
Extended Cascade Controller MCO 101	7
Advanced Cascade Controller MCO 102	8
Supported Configurations	10
Extension of Basic Cascade - Parameter group 25** control mode	11
Fixed Speed Pump Configuration	12
Master-Follower Configuration	13
Mixed Pump Configuration	14
Unequal Size Pump Configuration	15
Mixed Pump Configuration with Alternation	17
Soft Starters	18
Configuring the System	18
Setting-up the cascade parameters	18
Additional configuration for Multiple Drives	19
Closed Loop Control	20
Staging / De-staging of variable speed pumps based on Drive Speed	20
Staging / De-staging of fixed speed pumps based on Pressure Feedback	21
Control	21
Cascade Controller Features	21
Pump Status and Control	21
Manual Pump Control	22
Runtime Balancing	22
Pump Spin for unused pumps	23
Total lifetime hours	23
Alternation of the Lead Pump	23
Staging / Destaging in Mixed Pump Configurations	23
Override Staging /Destaging	24
Minimum Speed Destaging	24
Fixed speed only operation	24
Cascade Controller Parameters	25

Cascade CTL Option, 27-**	25
Control & Status, 27-0*	25
Configuration, 27-1*	26
Bandwidth Settings, 27-2*	27
Staging Speed, 27-3*	30
Staging Settings, 27-4*	31
Alternation Settings, 27-5*	33
Connections, 27-7*	34
Readouts, 27-9*	35
Master/Follower Application Note	38
<b>Index</b>	<b>41</b>

# 1 Extended and Advanced Cascade Controller Option

1

## 1.1 How to read these Operating Instructions

### 1.1.1 High Voltage Warning



The voltage of the frequency converter and the MCO 101 option card is dangerous whenever it is connected to mains. Incorrect installation of the motor or frequency converter may cause damage to the equipment, serious injury or death. Consequently, it is essential to comply with the instructions in this manual as well as local and national rules and safety regulations.

### 1.1.2 Safety Instructions



Prior to using functions directly or indirectly influencing personal safety (e.g. **Safe Stop** or other functions either forcing the motor to stop or attempting to keep it functioning) a thorough **risk analysis** and **system test** must be carried through. The system tests **must** include testing failure modes regarding the control signalling (analog and digital signals and serial communication).

- Make sure the frequency converter is properly connected to earth.
- Do not remove mains connections, motor connections or other power connections while the frequency converter is connected to power.
- Protect users against supply voltage.
- Protect the motor against overloading according to national and local regulations.
- The earth leakage current exceeds 3.5 mA.
- The [OFF] key is not a safety switch. It does not disconnect the frequency converter from mains.

### 1.1.3 Avoid unintended Start

While the frequency converter is connected to mains, the motor can be started/stopped using digital commands, bus commands, references or via the Local Control Panel.

- Disconnect the frequency converter and the MCO 101 option card from mains whenever personal safety considerations make it necessary to avoid unintended start of any motors.
- To avoid unintended start, always activate the [OFF] key before changing parameters.

### 1.1.4 Software Version

**Extended Cascade Controller Option for**  
**VLT AQUA Drive FC 200**  
 Operating Instructions  
 Software version: 1.33







These Operating Instructions can be used with all Extended Cascade Controller options with software version 1.33.

1

**NB!**

MCO 101/102 is software supported from version 1.24 onwards.

### 1.1.5 Symbols

When reading through this Operating Instructions, you will come across various symbols that require special attention.

The symbols used are the following:



Indicates a general warning.

**NB!**

Indicates something to be noted by the reader.



Indicates a high-voltage warning.

## 1.2 Safety and Caution

### 1.2.1 Safety



Rotating shafts and electrical equipment can be hazardous. Therefore, it is strongly recommended that all electrical work conform to National Electrical Code (NEC) and all local regulations. Installation, start-up and maintenance should be performed only by qualified personnel.

Factory recommended procedures, included in this manual, should be followed. Always disconnect electrical power before working on the unit. Although shaft couplings or belt drives are generally not furnished by the manufacturer, rotating shafts, couplings and belts must be protected with securely mounted metal guards that are of sufficient thickness to provide protection against flying particles such as keys, bolts and coupling parts. Even when the motor is stopped, it should be considered "alive" as long as its controller is energized. Automatic circuits may start the motor at any time. Keep hands away from the output shaft until the motor has completely stopped and power is disconnected from the controller.

Motor control equipment and electronic controls are connected to hazardous line voltages. When servicing drives and electronic controls, there will be exposed components at or above line potential. Extreme care should be taken to protect against shock. Stand on an insulating pad and make it a habit to use only one hand when checking components. Always work with another person in case of an emergency. Disconnect power whenever possible to check controls or to perform maintenance. Be sure equipment is properly grounded. Wear safety glasses whenever working on electric control or rotating equipment.

#### Safety Guidelines

1. The drive must be disconnected from the AC line before any service work is done.
2. The "Stop/Off" key on the of the drive does not disconnect the equipment from the AC line and is not to be used as a safety switch.
3. Correct protective grounding of the equipment must be established. The user must be protected against supply voltage and the motor must be protected against overload in accordance with applicable national and local regulations.
4. Ground currents are higher than 3 mA.

**Warning against Unintended Start**

1. While the drive is connected to the AC line, the motor can be brought to a stop by means of external switch closures, serial bus commands or references. If personal safety considerations make it necessary to ensure that no unintended start occurs, these stops are not sufficient.
2. During programming of parameters, the motor may start. Be certain that no one is in the area of the motor or driven equipment when changing parameters.
3. A motor that has been stopped may start unexpectedly if faults occur in the electronics of the drive, or if an overload, a fault in the supply AC line or a fault in the motor connection or other fault clears.
4. If the "Local/Hand" key is activated, the motor can only be brought to a stop by means of the "Stop/Off" key or an external safety interlock



**NB!**  
It is responsibility of user or person installing drive to provide proper grounding and branch circuit protection for incoming power and motor overload according to National Electrical Code (NEC) and local codes.

The Electronic Thermal Relay (ETR) in UL listed VLTs provides Class 20 motor overload protection in accordance with NEC in single motor applications, when par. is set for ETR TRIP 1, ETR TRIP 2, ETR TRIP 3, or ETR TRIP 4, and par. is set for rated motor (nameplate) current.

**1.2.2 Caution**



The frequency converter DC link capacitors remain charged after power has been disconnected. To avoid an electrical shock hazard, disconnect the frequency converter from the mains before carrying out maintenance. Wait at least as follows before doing service on the frequency converter:

Voltage (V)	Min. Waiting Time (Minutes)				
	4	15	20	30	40
200 - 240	0.25 - 3.7 kW	5.5 - 45 kW			
380 - 480	0.37 - 7.5 kW	11 - 90 kW	110 - 250 kW	315 - 1000 kW	
525-600	0.75 kW - 7.5 kW	11 - 90 kW			315 - 1200 kW
525-690		11 - 90 kW	45 - 400 kW	450 - 1200 kW	

Be aware that there may be high voltage on the DC link even when the LEDs are turned off.

**1.3 Introduction to MCO 101 and 102**

MCO 101 and 102 are add-on options extending the supported number of pumps and the functionalities of the in-built cascade controller in the VLT® AQUA Drive.

The extended cascade controller can be used in two different modes.

It can either be used with the extended features controlled by parameter group 27\*\* or it can be used to extend the number of available relays for the Basic cascade controlled by parameter group 25\*\*.

When one of the cascade options are installed only group 27\*\* will appear. In case the option is supposed to extend the relays in the in-built cascade controller group 25\*\*, the basic cascade can be enabled in par. 27-10, where after group 25\*\* will be visible in the main menu again. If par. 27-10 is set to Basic Cascade only, the basic cascade functionality will be available, only extended with 3 relays to a total of 5 relays.

When using group 27\*\* Extended / Advanced Cascade Control, the systems with pump alternation can be set-up with 2 relays per pump, which reduces the need for external equipment.

With MCO 101, a total of 5 relays can be used for cascade and with MCO 102, a total of 8 pumps can be controlled.

**NB!**  
If MCO 102 is installed, the relay option MCB 105 can extend the number of relays to 13.

**Application**

Cascade control is a common control system used to control parallel pumps or fans in an energy efficient way.

The Cascade Controller option provides the capability to control multiple pumps configured in parallel in a way that makes them appear as a single larger pump.

When using Cascade Controllers, the individual pumps are automatically turned on (staged) and turned off (de-staged) as needed in order to satisfy the required system output for flow or pressure. The speed of pumps connected to VLT AQUA Drives is also controlled to provide a continuous range of system output.

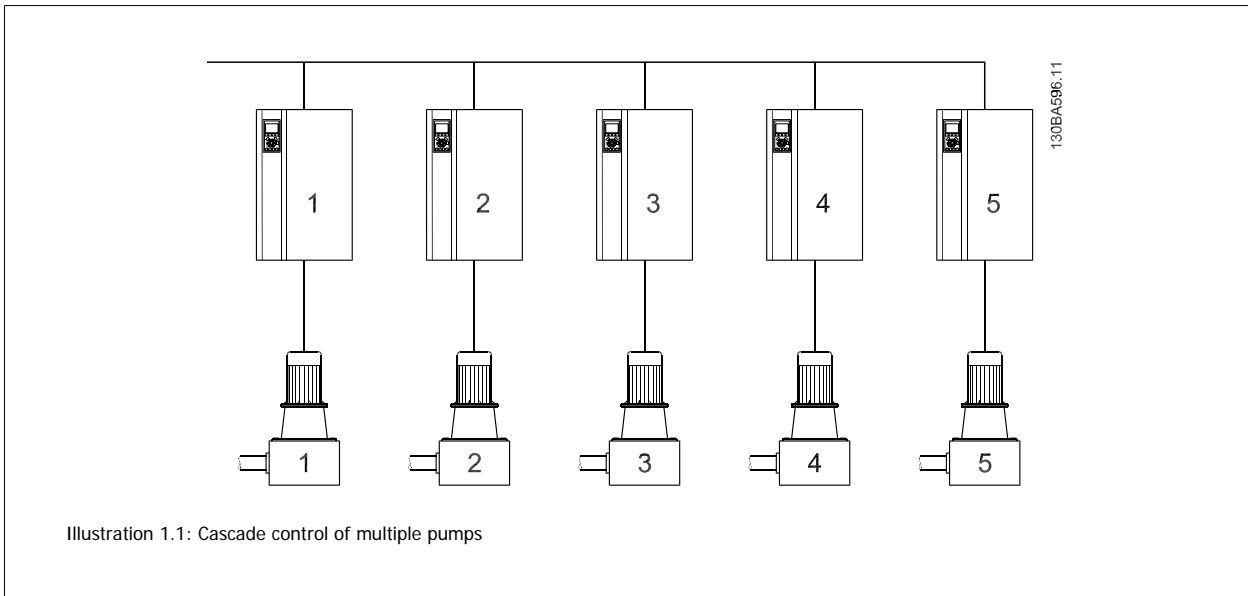

The Cascade Controllers are optional hardware and software components that can be added to the VLT AQUA Drive. It consists of an option board containing 3 relays that is installed in the B option location on the Drive. Once options are installed the parameters needed to support the Cascade Controller functions will be available through the control panel in the 27-\*\* parameter group. The Extended Cascade Controller offers more functionality than the Basic Cascade Controller. It can be used to extend the Basic Cascade with 3 relays and even to 8 relays with the Advanced Cascade Control card installed.

While the Cascade controller is designed for pumping applications and this document describes the cascade controller for this application, it is also possible to use the Cascade Controllers for any application requiring multiple motors configured in parallel.

**Master/Follower Operation**

The Cascade Controller software runs from a single VLT AQUA Drive with the Cascade Controller option card installed. This frequency converter is referred to as the Master Drive. It controls a set of pumps each controlled by a frequency converter or connected directly to mains through a contactor or through a soft starter.

Each additional frequency converter in the system is referred to as a Follower Drive. These frequency converters do not need the Cascade Controller option card installed. They are operated in open loop mode and receive their speed reference from the Master Drive. The pumps connected to these frequency converters are referred to as Variable Speed Pumps.

Each additional pump connected to mains through a contactor or through a soft starter is referred to as a Fixed Speed Pump.

Each pump, variable speed or fixed speed, is controlled by a relay in the Master Drive. The frequency converter with the Cascade Controller option card installed has five relays available for controlling pumps. Two (2) relays are standard in the FC and additional 3 relays are found on the option card MCO 101 or 8 relays and 7 digital inputs on option card MCO 102.

The difference between MCO 101 and MCO 102 is mainly the number of optional relays being made available for the FC. When MCO 102 is installed, the relays option card MCB 105 may be mounted in the B-slot.

The Cascade Controller is capable of controlling a mix of variable speed and fixed speed pumps. Possible configurations are described in more detail in the next section. For simplicity of description within this manual, Pressure and Flow will be used to describe the variable output of the set of pumps controlled by the cascade controller.

### 1.3.1 Extended Cascade Controller MCO 101

The MCO 101 option includes 3 pieces of change-over contacts and can be fitted into option slot B.

**Electrical Data:**

Max terminal load (AC)	240 V AC 2A
Max terminal load (DC)	24 V DC 1 A
Min terminal load (DC)	5 V 10 mA
Max switching rate at rated load/min load	6 min <sup>-1</sup> /20 sec <sup>-1</sup>

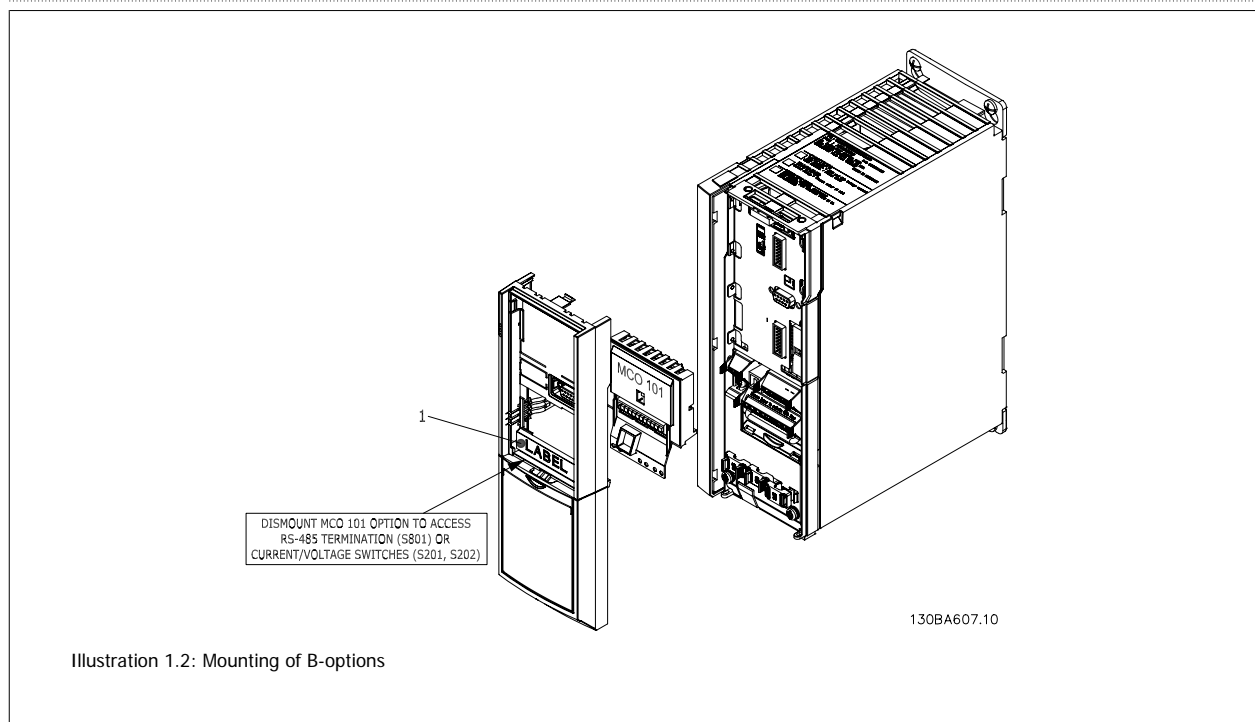



Illustration 1.2: Mounting of B-options



**Warning Dual supply**



**NB!**  
The label **MUST** be placed on the LCP frame as shown (UL approved).



How to add the MCO 101 option:

- The power to the frequency converter must be disconnected.
- The power to the live part connections on relay terminals must be disconnected.
- Remove the LCP, the terminal cover and the cradle from the FC 202.
- Fit the MCO 101 option in slot B.

1

- Connect the control cables and relief the cables by the enclosed cable strips.
- Various systems must not be mixed.
- Fit the extended cradle and terminal cover.
- Replace the LCP
- Connect power to the frequency converter.

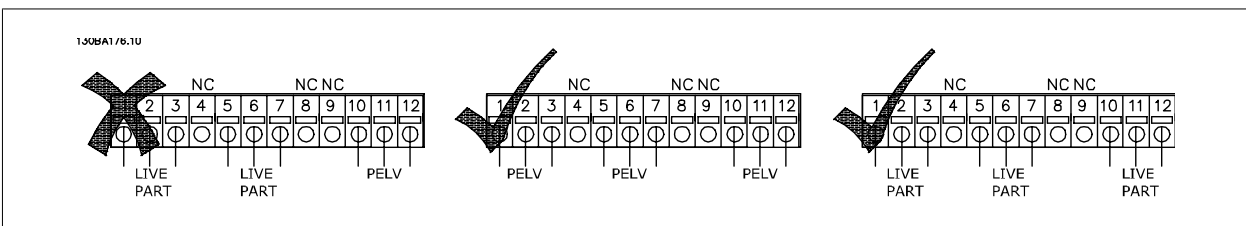
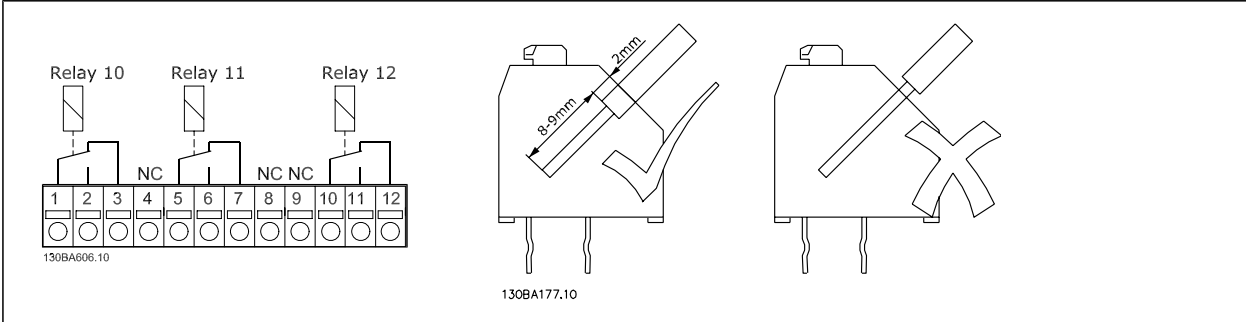
**Wiring the Terminals**





Do not combine low voltage parts and PELV systems.

**1.3.2 Advanced Cascade Controller MCO 102**

The MCO 102 option supports a maximum of 8 pumps and is able to alternate the lead pump with 2 frequency converter relays per pump. This reduces the need for external auxiliary switches as well as cost of installation.

When MCO 102 (C-option) is used, the number of relays can be increased to a total of 13 by adding the MCB 105 (B-option).



**NB!**  
Before start, interrupt the power supply to the frequency converter. Never install an option card into the frequency converter during operation.

**Electrical Data:**

Max terminal load (AC)	240 V AC 2A
Max terminal load (DC)	24 V DC 1 A
Min terminal load (DC)	5 V 10 mA
Max switching rate at rated load/min load	6 min <sup>-1</sup> /20 sec <sup>-1</sup>



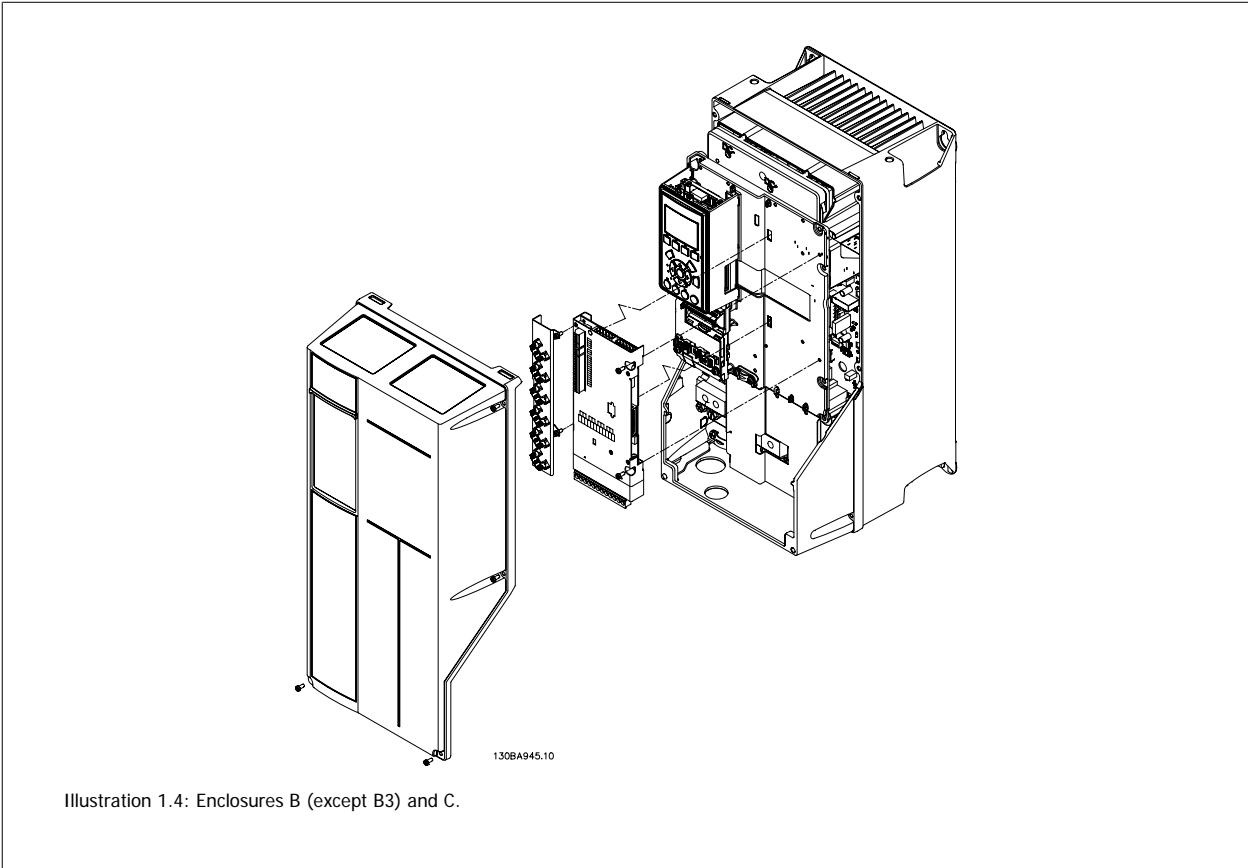
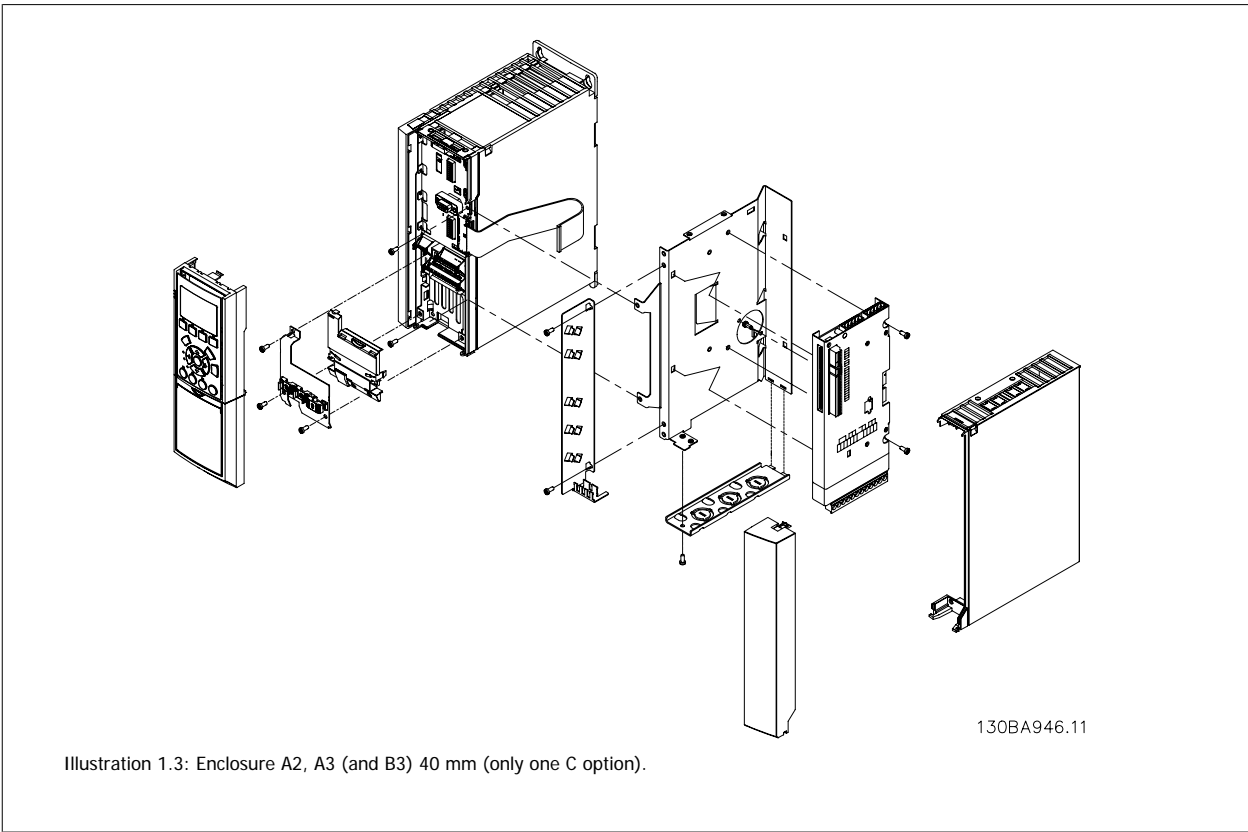

1

**How to add the MCO 102 option:**

- The power to the frequency converter must be disconnected.
- The power to the live part connections on relay terminals must be disconnected.
- Remove the LCP, the terminal cover and the cradle from the FC 202.
- Fit the MCO 102 option in slot B.
- Connect the control cables and relief the cables by the enclosed cable strips.
- Various systems must not be mixed.
- Fit the extended cradle and terminal cover.
- Replace the LCP
- Connect power to the frequency converter.

The VLT Advanced Cascade Control Card MCO 102 option is exclusively intended for use in option slot C1. The mounting position of C1 options is shown in the drawing below.

**Wiring the Terminals:**

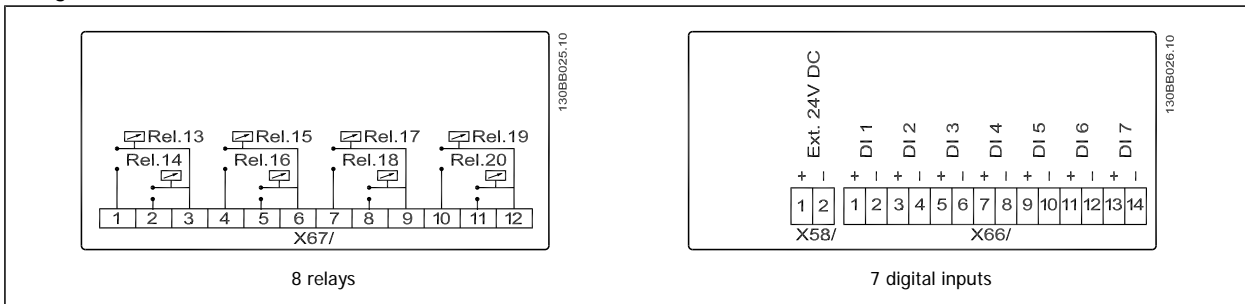

Table 1.1: Advanced Cascade Controller MCO 102 terminal connections

Some items are needed for the installation of a C-option mounting kit (depending on the enclosure):

Type	Description	Ordering number
<b>Options:</b>		
MCF 105	Mounting Kit frame size A2 and A3 (40mm for one C Option)	130B7530
MCF 105	Mounting Kit Frame size A5	130B7532
MCF 105	Mounting Kit Frame size B,C,D,E ,F1 and F3 (Except B3)	130B7533
MCF 105	Mounting Kit frame size B3 (40mm for one C Option)	130B1413
<b>Accessory Bag:</b>		
MCO 102	Accessory Bag	130B0152

## 1.4 Supported Configurations

The Extended- and Advanced Cascade Controller support a variety of different pump and Drive configurations. All of these configurations must have at least one variable speed pump, controlled by a VLT AQUA Drive, with the Extended- and Advanced Cascade Controller option card installed. They support from 1 to 8 additional pumps each connected to either a Danfoss VLT Drive with Master / Follower or to mains through a contactor or soft starter for a direct online system.

When setting-up the system, it is necessary to create a hardware configuration, which communicate to the Master, how many pumps and drives are connected. The necessary hardware is explained in the following hardware configuration examples.

**The following describes the features and how to use the extended cascade by means of parameters in group 27:**

### 1.4.1 Extension of Basic Cascade - Parameter group 25\*\* control mode

#### Use of the extended cascade option MCO 101 as an extension of the built-in basic cascade in the drive

In applications already controlled by the built-in cascade controller in group 25\*\*, the option card can be used to extend the numbers of relays for cascade control. For instance if a new pump is added to the system. It can also be used in case it is wanted to alternate the lead pump in systems with more than 2 drives, which is the limit for the basic cascade without MCO 101 option installed.

Install the option in slot B, enable the Basic cascade in par. 27-10. Please refer to AQUA programming guide for parameter group 25\*\* settings.

Example: Electrical wiring diagram for the external equipment needed for systems with alternating lead pump of 4 pumps using Basic cascade and MCO 101 as relay extension.

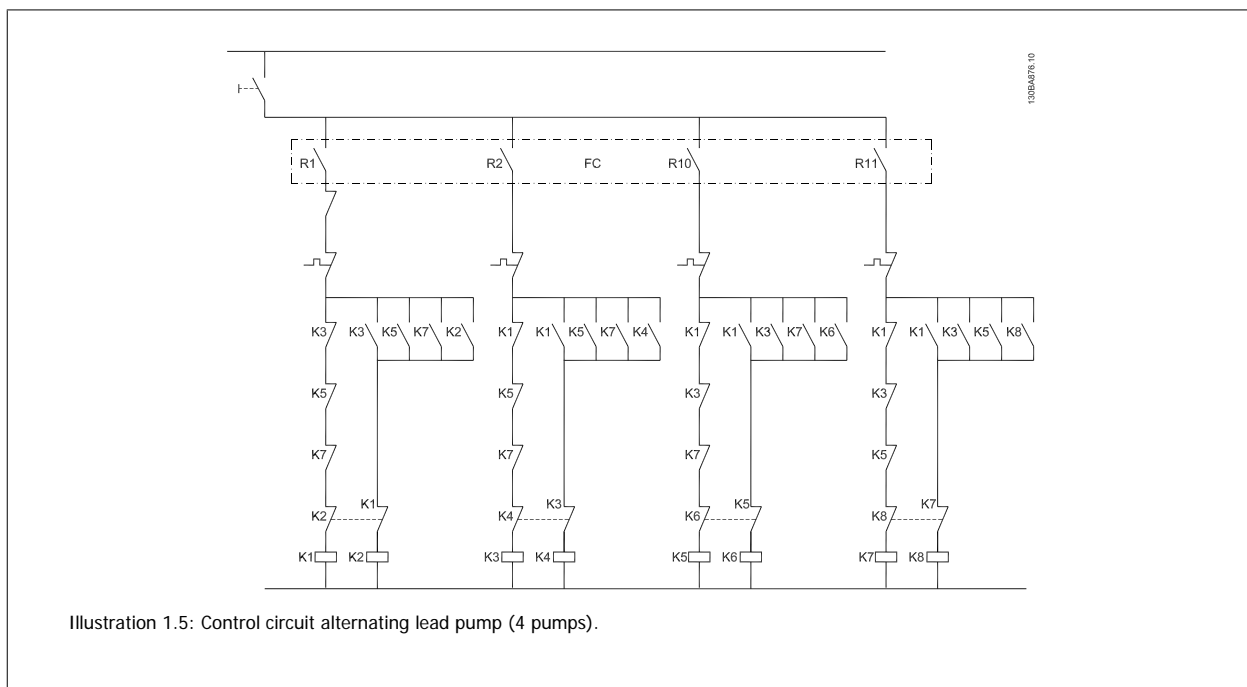

Illustration 1.5: Control circuit alternating lead pump (4 pumps).

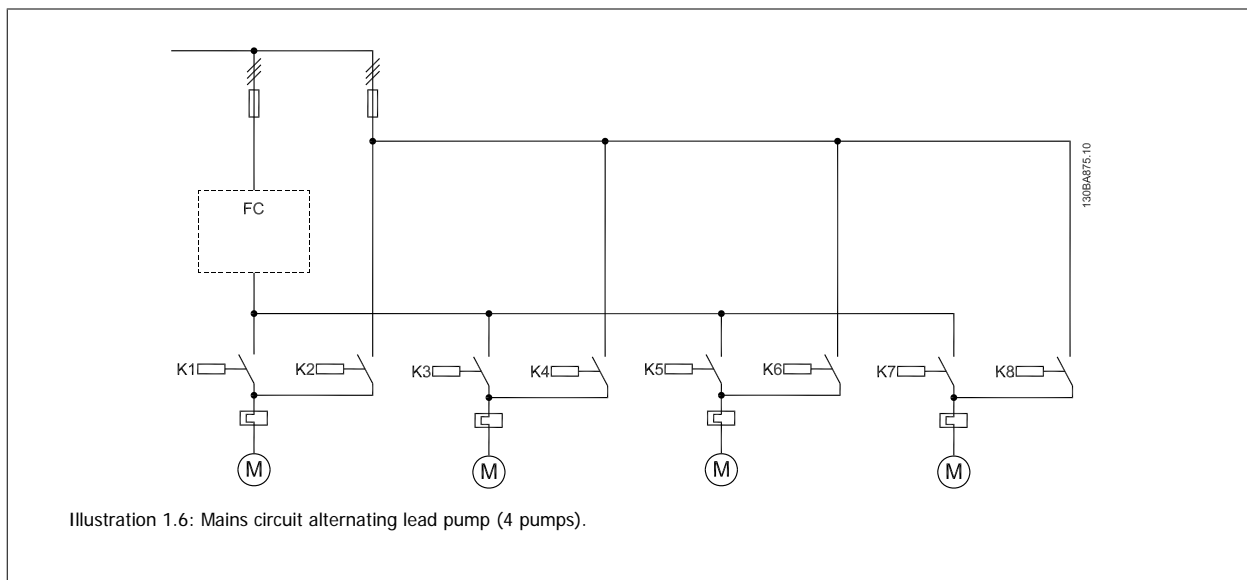

Illustration 1.6: Mains circuit alternating lead pump (4 pumps).

### 1.4.2 Fixed Speed Pump Configuration

1

In this configuration a single Drive controls one variable speed pump and up to 7 fixed speed pumps. The fixed speed pumps are staged and de-staged as needed through contactors direct online. The single pump connected to the Drive provides the finer level of control needed between the stages.

The direct online pumps are staged or de-staged depending on the feedback.

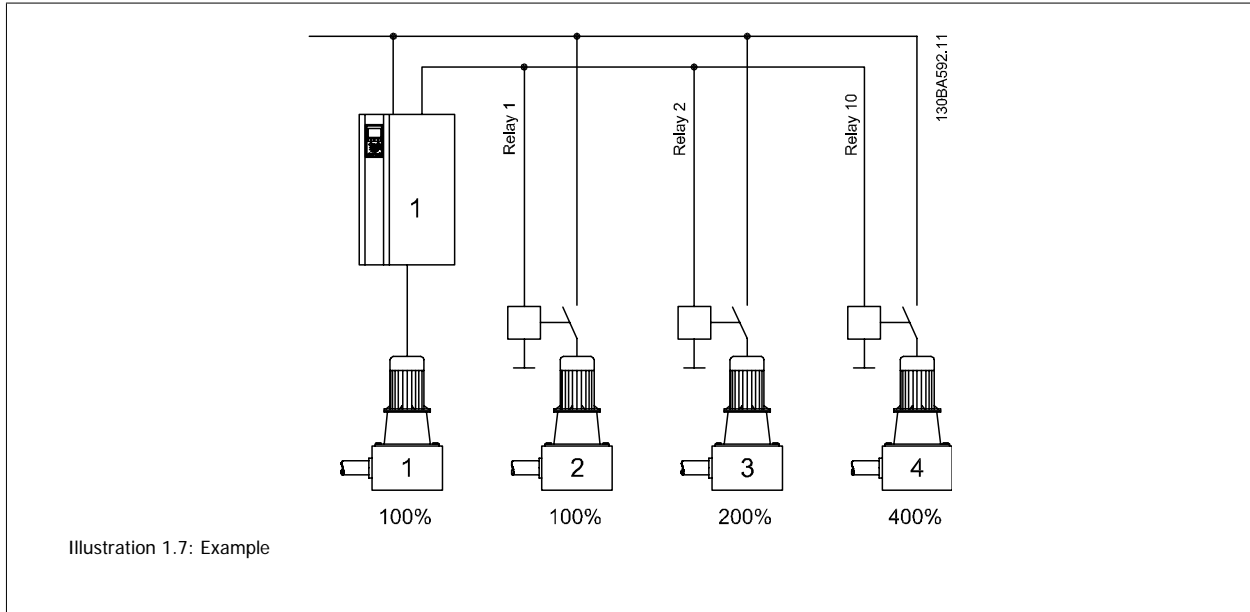

**For this configuration relay selections in Group 27-7\* "Connections" are as follows:**

- 27-70 RELAY 1 → [73] Pump 2 to Mains
- 27-71 RELAY 2 → [74] Pump 3 to Mains
- 27-72 RELAY 10 → [75] Pump 4 to Mains
- 27-73 RELAY 11 → [0] Standard Relay
- 27-74 RELAY 12 → [0] Standard Relay

The Fixed Speed Pump configuration provides a cost effective method for controlling up to 6 pumps. It is able to control system output by controlling the number of running pumps as well as the speed of the single variable speed pump. It will however produce wider pressure fluctuations during staging/destaging transitions and it may be less energy efficient than the Master-Follower configurations.

### 1.4.3 Master-Follower Configuration

In this configuration each pump is controlled by a frequency converter. All of the pumps and frequency converters must be of the same size. Staging and de-staging decisions are made based on the speed of the frequency converters. The constant pressure is controlled by the master drive operating in closed loop. The speed will be the same in all running pumps with extended control. Up to 6 pumps can be controlled (with Advanced Control up to 8 pumps).

In the Master/Follower mode, MCO 101 supports up to 6 pumps - MCO 102 up to 8 pumps. Please see *Master/Follower Operation Application for FC 200* (Annex A) for further details.

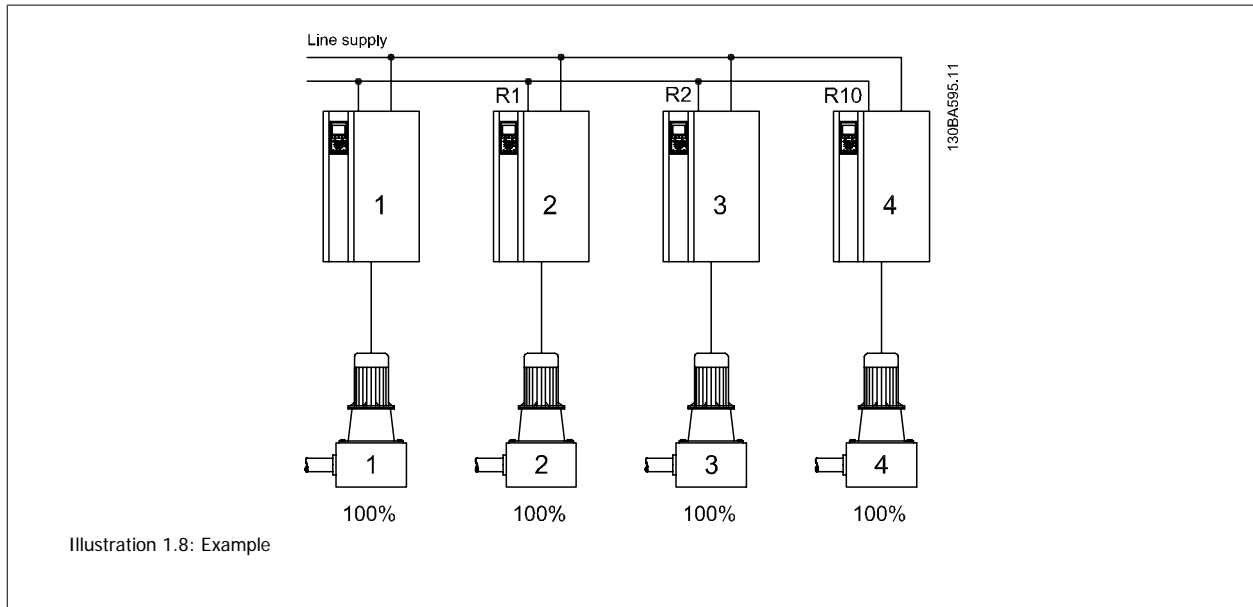

For this configuration relay selections in Group 27-7\* "Connections" are as follows:

- 27-70 RELAY 1 → [1] Drive 2 Enable
- 27-71 RELAY 2 → [2] Drive 3 Enable
- 27-72 RELAY 10 → [3] Drive 4 Enable
- 27-73 RELAY 11 → [0] Standard Relay
- 27-74 RELAY 12 → [0] Standard Relay

The master-follower configuration provides the gentlest transition from one stage to the next and the most energy efficient operation. For most installations the energy savings make this the most cost effective configuration.

The system will automatically runtime balance all pumps depending on the pump prioritization made in par. 27-16. The Master/Follower system will provide a certain level of redundancy. If the master drive trips, it will continue to control the follower drives.

MCB-107 External 24 VDC power supply can be added to increase the level of redundancy.

Furthermore it reduces wear and tear on pumps and motors. The relays set to [0] Std. Relay, can be used as general purpose relays, controlled by the parameters in group 5-4\*.

### 1.4.4 Mixed Pump Configuration

1

The Mixed Pump configuration supports a mix of variable speed pumps connected to Drives as well as additional fixed speed pumps. In this configuration all of the variable speed pumps and Drives must be the same size. The fixed speed pumps may be of different sizes. The variable speed pumps are staged on and staged off first based on Drive speed. The fixed speed pumps are then staged on last and staged off last based on the feedback pressure.

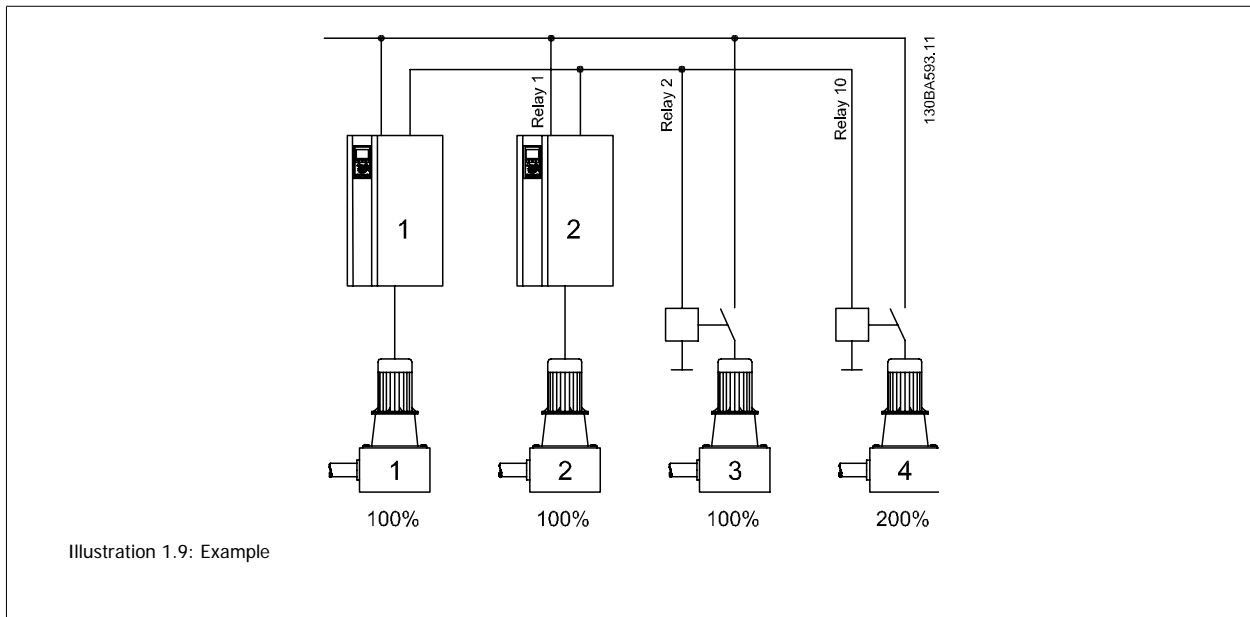

For this configuration relay selections in Group 27-7\* "Connections" are as follows:

- 27-70 RELAY 1 → [1] Drive 2 Enable
- 27-71 RELAY 2 → [74] Pump 3 to Mains
- 27-72 RELAY 10 → [75] Pump 4 to Mains
- 27-73 RELAY 11 → [0] Standard Relay
- 27-74 RELAY 12 → [0] Standard Relay

This configuration provides some of the benefits of the Master Follower configuration with some of the initial cost savings of the Fixed Speed configuration. It is a good choice when the extra capacity of the fixed pumps is rarely needed.

### 1.4.5 Unequal Size Pump Configuration

The Unequal Size Pump configuration supports a limited mix of fixed speed pumps in different sizes. It provides for the largest range of system output with the smallest number of pumps.

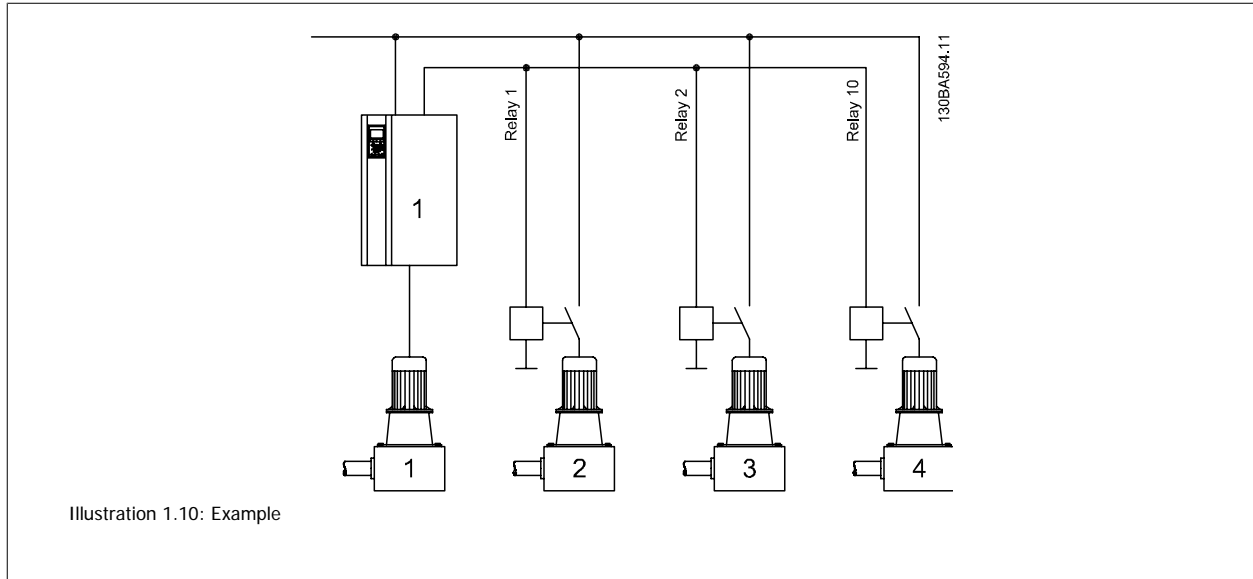

For this configuration relay selections in Group 27-7\* "Connections" are as follows:

- 27-70 RELAY 1 → [73] Pump 2 to Mains
- 27-71 RELAY 2 → [74] Pump 3 to Mains
- 27-72 RELAY 10 → [75] Pump 4 to Mains
- 27-73 RELAY 11 → [0] Standard Relay
- 27-74 RELAY 12 → [0] Standard Relay

Not all configurations of unequal size pumps are valid. For a configuration to be valid it must be possible to stage pumps in increments of 100% of the size of the Master Drive's variable speed pump. This is necessary since the variable speed pump must be able to control the output between the fixed speed stages.

#### Valid Configurations

100% is defined as the maximum flow produced by the pump connected to the Master Drive. The fixed speed pumps must be multiples of this size.

Variable Speed	Fixed Speed
100%	100% + 200%
100%	100% + 200% + 200%
100%	100% + 100% + 300%
100%	100% + 100% + 300% + 300%
100%	100% + 200% + 400%
100% + 100%	200%
100% + 100%	200% + 200%

(Other valid configurations are possible)

#### Invalid Configurations

Invalid configurations will still run but will not stage on all of the pumps. This is done to allow for limited operation if a pump fails or is interlocked in this configuration.

1

Variable Speed	Fixed Speed	
100%	200%	(no control between 100% and 200%)
100%	100% + 300%	(no control between 200% and 300%)
100%	100% + 200% + 600%	(no control between 400% and 600%)



### 1.4.6 Mixed Pump Configuration with Alternation

In this configuration is possible to alternate the Drive between two pumps along with controlling additional fixed speed pumps. The cascade controller will attempt to balance the running hours between all of the pumps as specified by the Runtime Balancing parameter.

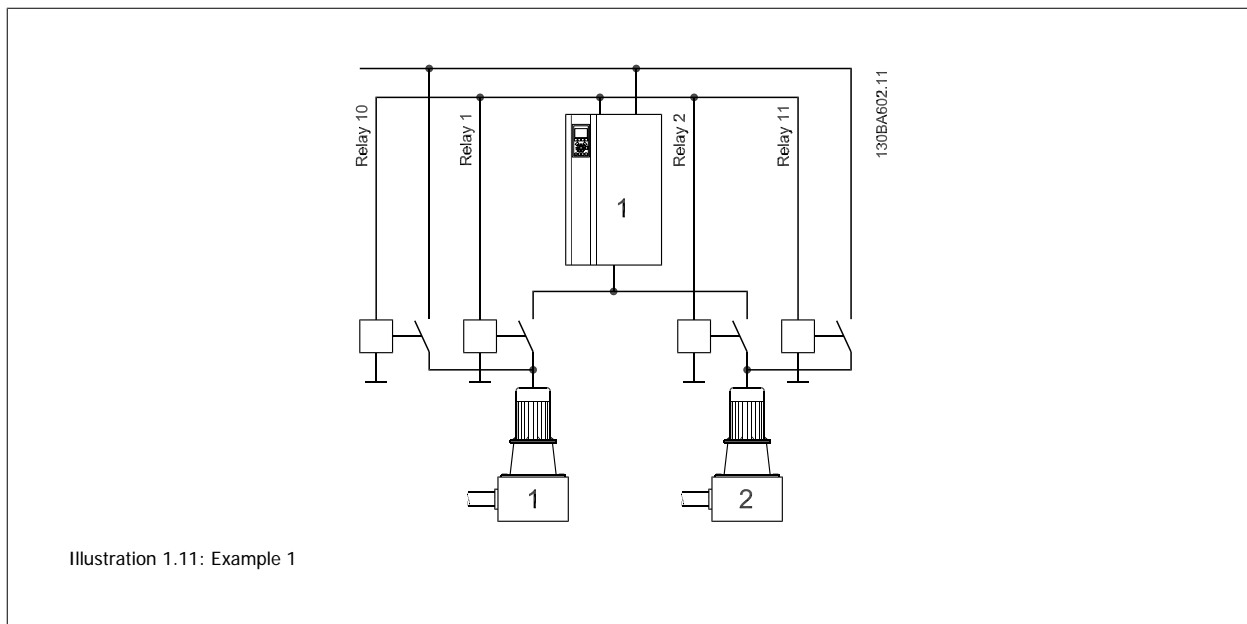

The two pumps can be either variable speed or fixed speed with equal running hours.

**For this configuration relay selections in Group 27-7\* "Connections" are as follows:**

- 27-70 RELAY 1 → [8] Pump 1 to Drive 1
- 27-71 RELAY 2 → [16] Pump 2 to Drive 1
- 27-72 RELAY 10 → [72] Pump 1 to Mains
- 27-73 RELAY 11 → [73] Pump 2 to Mains
- 27-74 RELAY 12 → [0] Standard Relay

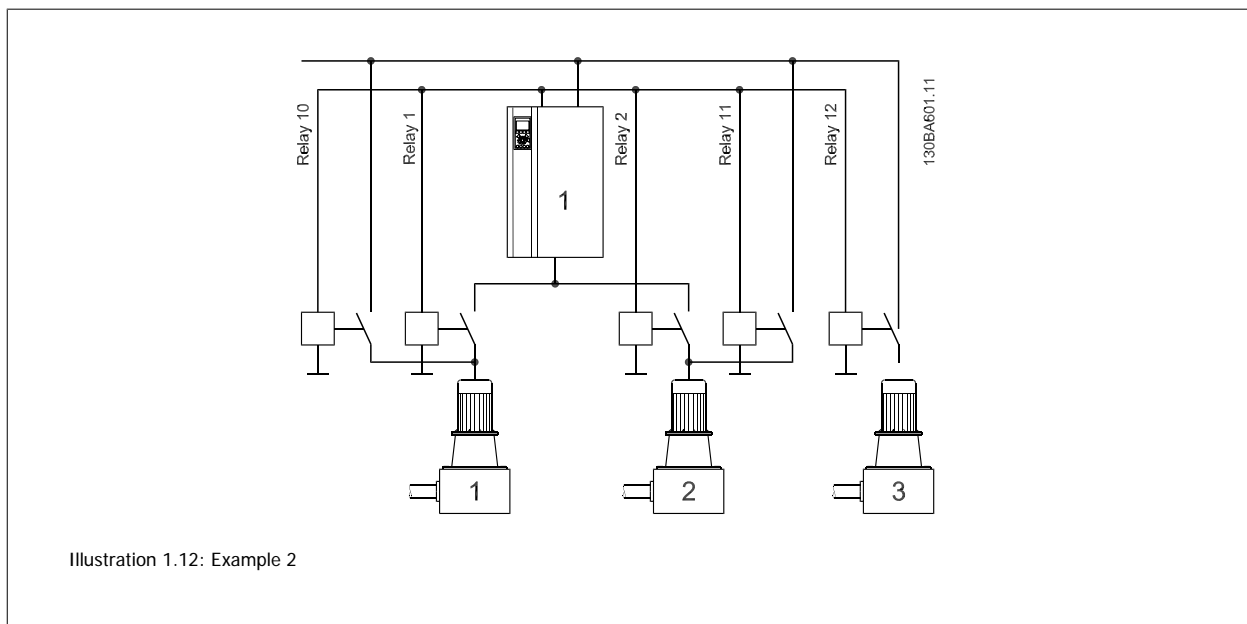

The first two pumps can be either variable speed or fixed speed with equal running hours between all three pumps as long as the system demand is typically greater than 1 pump.

1

For this configuration relay selections in Group 27-7\* "Connections" are as follows:

- 27-70 RELAY 1 → [8] Pump 1 to Drive 1
- 27-71 RELAY 2 → [16] Pump 2 to Drive 1
- 27-72 RELAY 10 → [72] Pump 1 to Mains
- 27-73 RELAY 11 → [73] Pump 2 to Mains
- 27-74 RELAY 12 → [74] Pump 3 to Mains

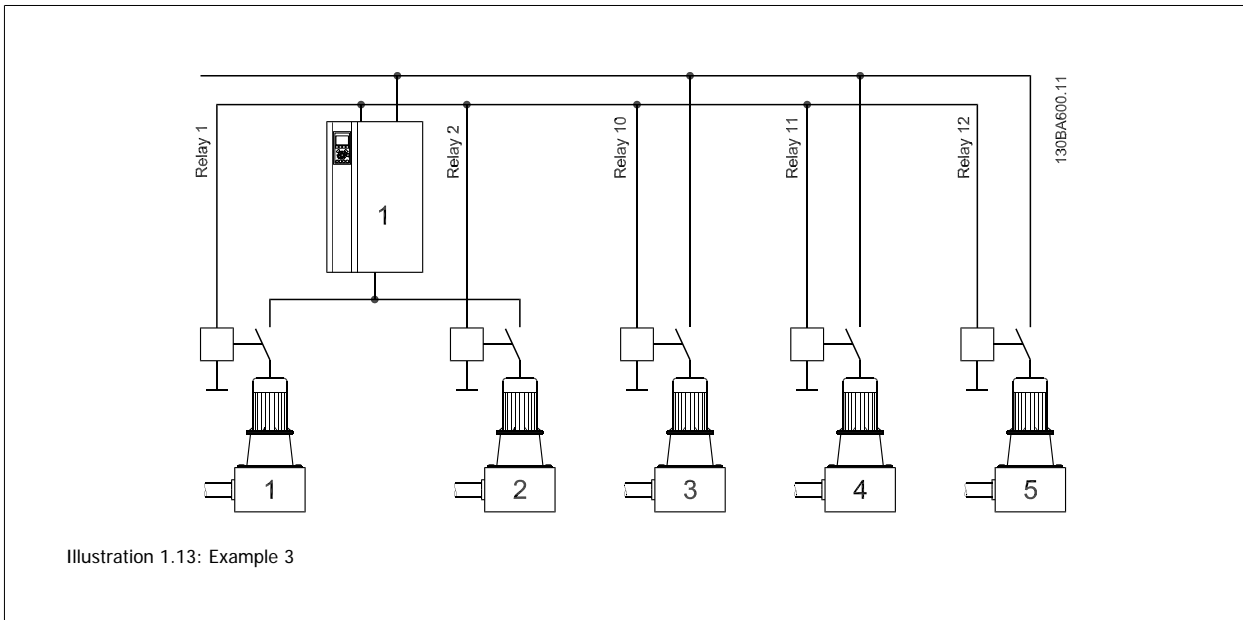

The first two pumps alternate each with 50% of the running hours. The fixed speed pumps turned on and off as needed with equal running time between them.

For this configuration relay selections in Group 27-7\* "Connections" are as follows:

- 27-70 RELAY 1 → [8] Pump 1 to Drive 1
- 27-71 RELAY 2 → [16] Pump 2 to Drive 1
- 27-72 RELAY 10 → [74] Pump 3 to Mains
- 27-73 RELAY 11 → [75] Pump 4 to Mains
- 27-74 RELAY 12 → [76] Pump 5 to Mains

### 1.4.7 Soft Starters

Soft Starters can be used in place of contactors for any configuration using fixed speed pumps. If Soft Starters are selected, they must be used for ALL fixed speed pumps. Mixing Soft Starters and contactors will result in an inability to control the output pressure during staging and de-staging transitions. When using soft-starters a delay will be added from staging signal occurs until staging takes place. The delay is necessary due to the ramp time of the fixed speed pump because of the soft-starter.

## 1.5 Configuring the System

The Extended- and Advanced Cascade Controller can be quickly configured using many of the default parameters. However, it is first necessary to describe the configuration of frequency converters and pumps in the system and to describe the desired level of control of the systems output.

### 1.5.1 Setting-up the cascade parameters

Parameter groups 27-1\* "Configuration" and 27-7\* "Connections" are used to define the hardware configuration of the installation. Start the configuration of the cascade controller by selecting values for the parameters in the 27-1\* "Configuration" group.

Parameter no.	Description
27-10	Cascade Controller can be used to enable or disable the Extended Cascade Controller. The Mixed Pump selection is the general selection for the cascade controller. If using one Drive per pump the Master-Follower configuration can be selected reducing the number of parameters needed to setup the system.
27-11	Number of Drives
27-12	Number of Pumps - Will default to the Number of Drives.
27-14	Pump Capacity for each pump (Indexed Parameter) - If all of the pumps are the same size the default values shall be used. To adjust: first choose pump, click OK and adjust the capacity.
27-16	Runtime Balancing for each pump (Indexed Parameter) - If the system should equally balance the running hours between the pumps then use the default values.
27-17	Motor Starters - All fixed speed pumps must be the same.
27-18	Spin Time for Unused Pumps - Depends on the size of the pumps.

Next, the relays used to turn pumps on and off need to be defined. Parameter group 27-7\* "Connections" provides a list of all of the available relays:

- Each Follower Drive in the system needs to have one relay assigned to enable/disable the Drive as needed.
- Each Fixed speed pump needs to have one relay assigned to control the contactor or enable the soft starter to turn the pump on/off.
- If it necessary to have a single Drive alternate between two pumps then additional relays need to be assigned to provide this capability.

Any unused relays will be available for other functions through the parameter group 5-4\* Relays.

### 1.5.2 Additional configuration for Multiple Drives

When more than one frequency converter is used in the cascade controller it is necessary for the Master Drive to tell the Follower Drives how fast to run. This is accomplished through a digital signal between the frequency converters.

The master drive must use a digital output pin to output the required frequency for all of the frequency converters. All of the frequency converters always run at the same speed. Par. 5-01 is set to [Output], par. 5-30 to [Pulse output] and par. 5-60 to [Cascade ref.].

Each of the follower drives must then be set to open loop and must use a digital input as their speed reference. This can be done by setting par. 1-00 Configuration Mode to [0] Open Loop and par. 3-15 to selection [7] Frequency Input 29 and par. 5-13 to [32] Pulse input.

The 3-41 Ramp Up Time and 3-42 Ramp Down Time must be the same for the master drive and for all of the follower drives in the system.

These ramps should be set fast enough to enable the PID controller to maintain control of the system.

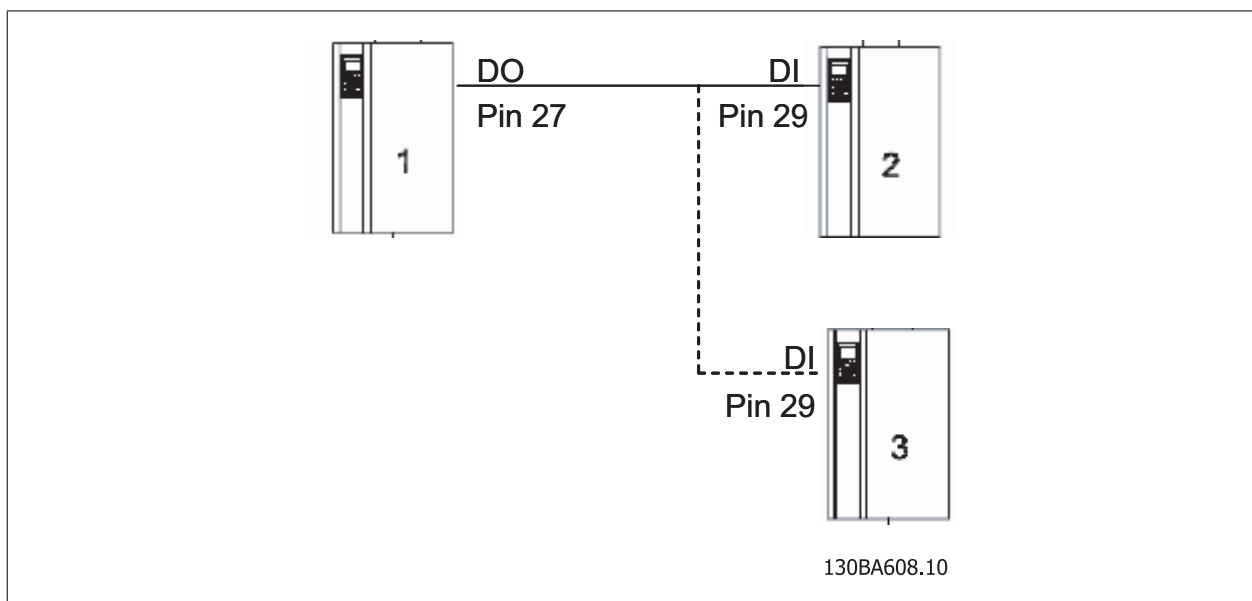

1

### 1.5.3 Closed Loop Control

The master drive is the primary controller for the system. It monitors the output pressure, adjusts the speed of the frequency converters and decides when to add or remove stages. To perform this function the master drive must be setup in closed loop mode with a feedback sensor connected to an analog input of the Drive.

The PID controller of the master drive must be setup to match the needs of the installation. Setting up the PID parameters is described in the *VLT AQUA Drive Programming Guide* and will not be covered in this manual. Please see also application note Master/Follower Operation, included in this manual.

### 1.5.4 Staging / De-staging of variable speed pumps based on Drive Speed

In Master-Follower configurations and Mixed Pump configurations the variable speed pumps are staged and de-staged based on the speed of the Drives.

Staging occurs when the speed of the Drives has reached the value in parameter 27-31 (27-32) Stage on Speed. At this speed the system pressure is still maintained but the pumps are beginning to operate outside of their peak efficiency points. Staging on an additional pump will lower the speed of all of the running pumps and provide a more energy efficient operation.

De-staging occurs when the speed of the Drives drops below the value in parameter 27-33 (27-34) Stage Off Speed. At this speed the system pressure is still maintained but the pumps are beginning to operate below their peak efficiency points. De-staging a pump will cause the speed of the Drives to increase into a more energy efficient range.

Parameters 27-31 (27-32) Stage on Speed and 27-33 (27-34) Stage Off Speed are installation dependent. These parameters are indexed parameters with one set of entries for each pump stage.

The stage on and de-stage off speed can be auto tuned during automation or set manually. If Auto-tune is enabled the system will start operation using default settings or the pre settings done by the user in P27-31 (27-32) and 27-33 (27-34) before enabling the auto-tune.

The goal is to find the stage on and off speeds where the system is most energy efficient. See drawing below.

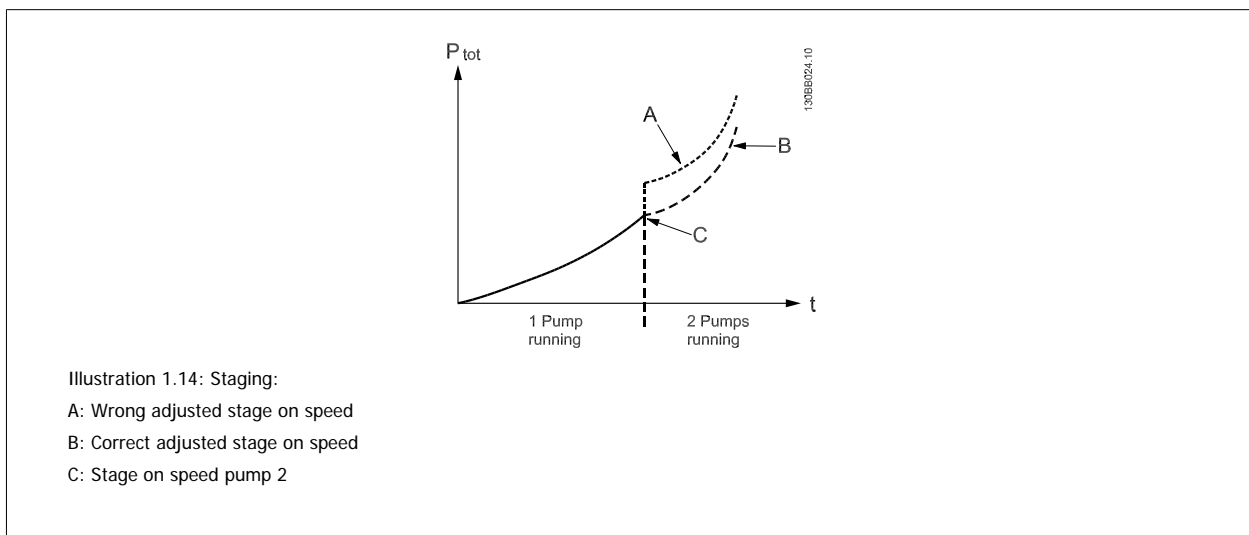

When the system is set in operation it will monitor the actual energy consumption and fine adjust every time a stage or de-stage takes place.

This feature will over time ensure the most energy efficient way of operation taking into account wear and tear of the pump system.

Danfoss has available the Multiple Unit Staging Efficiency Calculator (MUSEC), a free software program available on the Danfoss web site. By entering pump and system data, MUSEC provides the optimal settings for the Stage on Speed and Stage off Speed parameters.

### 1.5.5 Staging / De-staging of fixed speed pumps based on Pressure Feedback

Fixed speed pumps are staged based on a drop in system pressure. And are de-staged based on an increases in system pressure.

Since it is undesirable to have pumps turning on and off rapidly, an acceptable range of system pressure needs to be defined along with a period of time the pressure is allowed to be outside of this band before staging or de-staging occurs. These values are set through parameters 27-20 "Normal Operating Range" 27-23 "Staging Delay" and 27-24 "De-staging Delay".

These parameters are installation dependent and should be set to meet the requirements of the system.

#### Automatic stage / de-stage threshold

The speed of the variable speed pump at the point of staging or de-staging is defined by stage threshold or a de-stage threshold. These settings are usable in order to secure as minimum over or undershoot in the pressure at staging or de-staging.

Compared to the basic cascade built in the drive, these settings can be auto tuned in extended and advanced cascade options MCO101 and MCO102.

If enabled the auto tune of staging and de-staging threshold will monitor the feedback in the point of staging or de-staging and fine adjust the settings every time a staging takes place in order to keep the system optimized over time taking into account wear and tear of the pumps.

New parameter descriptions:			
Number	Display name	Range	Default
27-30	Auto Tune Staging Speeds	{Disabled [0], Enabled [1]}	Enabled [1]
27-40	Auto Tune Staging Settings	{Disabled [0], Enabled [1]}	Enabled [1]

## 1.6 Control

Once the Cascade controller has been configured it can be enabled or disabled through parameter 27-10 "Cascade Controller". To start the cascade controller the Master Drive needs to be started as a normal Drive through the LCP or through field buss communications. It will then attempt to control the system pressure by varying the speed of the FC and by staging on and off pumps as needed.

Two stop functions are provided by the cascade controller. One function quickly stops the system. The other stages off pumps in a sequence, allowing for a pressure controlled stop. For the VLT AQUA Drive equipped with Safe Stop, Terminal 37 will turn off all relays and coast the Master drive. If any of the digital inputs are set to [8] "Start" and the corresponding terminal is used to control the starting and stopping of the drive then setting the terminal to 0 volts will turn off all relays and coast the Master drive. Pressing the OFF button on the LCP will cause a sequenced de-staging of all of the running pumps.

## 1.7 Cascade Controller Features

### 1.7.1 Pump Status and Control

The 27-0\* group of parameters provides a convenient place to check on the status of the Cascade Controller and to control individual pumps. In this parameter group it is possible to select a specific pump to view the current status, the current running hours, and the total lifetime hours. From the same location an individual pump can be manually controlled for maintenance purposes.

The parameter group is organized as follows:

Parameter	Pump 1	Pump 2	Pump 3	Pump ...
27-01 Status	On Drive	Ready	Offline-off	
27-02 Control	No Operation	No Operation	No Operation	
27-03 Current Hrs	650	667	400	
27-04 Lifetime Hrs.	52673	29345	30102	

Navigate to the 27-0\* group on the LCP.

Use right and left arrows on the LCP to select the pump. Use up and down arrows on the LCP to select the parameter.

## 1

### 1.7.2 Manual Pump Control

The Extended Cascade Controller allows for complete control of each pump in the system. Through parameter 27-02 pumps can be individually controlled through their selected relays. A pump can be turned on or off outside of the control of the Extended Cascade Controller or can be forced to alternate the lead.

This parameter is different than other value related parameters in that selecting one of these options will cause the action to occur and then the parameter will revert back to its default state.

**The choices are as follows:**

- No Operation - Default.
- Online - Makes the pump available to the Extended Cascade Controller.
- Alternate On - Forces the selected pump to be the lead pump.
- Offline-Off - Turns the pump off and makes it unavailable for cascading.
- Offline-On - Turns the pump on and makes it unavailable for cascading.
- Offline-Spin - Initiates a pump spin.

If any of the "Offline" selections are chosen the pump will no longer be available to the cascade controller until "Online" is selected.

**If a pump is taken offline through parameter 27-02 the cascade controller will attempt to compensate for the unavailable pump.**

- If "Offline-Off" is selected for a pump that is running, a different pump will be staged on to compensate for the loss of output.
- If "Offline-On" is selected for a pump that is currently off, a different pump will be staged off to compensate for the excess output.

### 1.7.3 Runtime Balancing

The Extended Cascade Controller is designed to balance the running hours between the available pumps. Parameter 27-16 provides a balancing priority for each pump in the system.

**Three levels of priority are available:**

- Balanced Priority 1
- Balanced Priority 2
- Spare Pump

The cascade controller selects a pump to be staged or destaged based on the pump's maximum capacity (27-14), the Current Runtime Hours (27-03), and the Runtime Balancing (27-16) parameter.

In selecting the pump to be turned on during staging the cascade controller will first attempt to evenly balance the current running hours for all of the pumps with a "Balanced Priority 1" in parameter 27-16.

If all of the Priority 1 pumps are running it will then try to evenly balance the pumps with "Balanced Priority 2" selected.

If all of the Priority 1 and 2 pumps are running it will then select a pumps with "Spare Pump" selected.

During destaging the reverse occurs. Spare Pumps are destaged first, followed by Priority 2 pumps, followed by Priority 1 pumps. At each priority level the pump with the largest Current Runtime Hours will be destaged first.

An exception to this occurs in Mixed Pump configurations with more than one Drive. All variable speed pumps are staged on before fixed speed pumps.

Variable speed pumps are also staged off before fixed speed pumps. Parameter 27-19 is used to reset the Current Runtime Hours for all of the pumps and restart the balancing process. This parameter will not affect the Total Lifetime Hours (27-04) for each pump. Total Lifetime Hours is not used for runtime balancing.

### 1.7.4 Pump Spin for unused pumps

For some installations not all of the pumps are needed or used on a regularly basis. When this occurs the Extended Cascade Controller will first try to balance the running hours between pumps by alternating when possible. If however it is unable to use a pump for 72 hours it will initiate a Pump Spin for that pump.

This feature is intended to make sure that no pump is allowed to sit idle for an extended period of time. The Spin Time can be set with parameter 27-18. The Spin Time should be long enough to ensure that the pump stays in good working condition but short enough not to over pressure the system. Setting 27-18 to zero disables the function.

The Extended Cascade Controller will not compensate for the extra pressure generated during a pump spin. It is advisable to keep the Spin Time as short as possible to prevent damage caused by over pressuring the output.

### 1.7.5 Total lifetime hours

For maintenance purposes the Extended Cascade Controller is designed to help you keep track of the total lifetime hours for each pump it controls.

The Pump Total Lifetime Hours parameter 27-04 displays a running total of the operating hours for each pump. This parameter is updated whenever a pump is running and is saved to non-volatile memory once every hour.

This parameter can also be set to an initial value to reflect the hours of operation for a pump before it was added to the system.

Lifetime hours will only be accumulated by the Cascade Controller if it is enabled and controlling the pump.

### 1.7.6 Alternation of the Lead Pump

In a configuration with multiple Drives, the Lead Pump is defined as the last variable speed pump running.

In a configuration with only a single Drive, the Lead Pump is defined as the pump connected to the Drive. More than one pump can be connected to the Drive through contactors controlled by the Master Drive's relays.

Through normal staging and destaging the cascade controller will alternate the Lead Pump to balancing running hours. It will also alternate the Lead Pump when starting the system or when exiting sleep mode.

However if the system demand stays below the maximum capacity of the Lead Pump for a long period of time without entering sleep mode then it will not alternate the pump. If this is likely the Lead Pump can be forced to alternate through a Time Interval parameter 27-52 or through a Time of Day parameter 27-54.

### 1.7.7 Staging / Destaging in Mixed Pump Configurations

Two methods are used to decide when pumps should be staged or destaged. The first is the speed of the Drives. The second is the feedback pressure going outside of the Normal Operating Range. In a Mixed Pump configuration with more than one Drive both methods are used.

In the following example, feedback is referred to as pressure.

#### **Staging:**

When the Master Drive receives a start command a variable speed pump is selected, and started using one of the available Drives.

If the system pressure drops, the speed of the Drive increases to meet the demand for more flow. While maintaining the pressure, if the Drive exceeds the Stage on Speed (27-31), and remains above that speed for the Staging Delay (27-23) time, the next variable speed pump is staged on. This repeats for all of the variable speed pumps.

1

If the cascade controller is still unable to maintain the system pressure with all of the variable speed pumps on at maximum, it will begin to stage on fixed speed pumps. A fixed speed pump will be staged on when the pressure goes below the setpoint by the Normal Operation Range (27-20) percentage and stays there for the Staging Delay (27-23) time. This repeats for all of the fixed speed pumps.

**Destaging:**

If the system pressure increases, the speed of all of the Drives decrease to match the system's reduced demand for flow. While maintaining pressure, if the Drive goes below the Stage off Speed (27-33) and stays there for the Destaging Delay (27-24) time, a variable speed pump will be staged off. This repeats for all of the variable speed pumps except the last one.

If the system pressure is still too high with only one Drive running at minimum speed, it will begin to destage fixed speed pumps. A fixed speed pump will be destaged when the pressure goes above the setpoint by the Normal Operating Range (27-20) percentage and stays there for the Destaging Delay (27-24) time. This repeats for all of the fixed speed pumps. This leaves only one variable speed pump running. If the system demand continues to drop the system will enter sleep mode.

### 1.7.8 Override Staging /Destaging

Normal staging and destaging handles most of the situations in typical applications. However sometimes it is necessary to respond rapidly to changes in system feedback pressure. In these cases the cascade controller is equipped to immediately stage and destage pumps in response to large changes system demand.

**Staging:**

When the system pressure drops by more than the Override Limit (27-21), the cascade controller will immediately stage on a pump to meet the demand for more flow.

If the system pressure continues to stay below the Override Limit (27-21) for the Override Hold Time (27-25) time, the cascade controller will then stage on the next pump. This repeats until all of the pumps are on or until the system pressure drops below the Override Limit.

**Destaging:**

When the system pressure increases rapidly above the Override Limit (27-21), the cascade controller will immediately destage a pump to try to reduce the pressure.

If the system pressure continues to stay above the Override Limit (27-21) for the Override Hold Time (27-25) time, the cascade controller will destage another pump. This will repeat until only the lead pump is left on or until the pressure stabilizes.

The Override Limit parameter 27-21 is set as a % of the Maximum Reference. It defines a point above and below the system Setpoint where Override staging and destaging will occur.

### 1.7.9 Minimum Speed Destaging

To reduce emergency usage the cascade controller will destage a pump if the Lead Pump is running at minimum speed for Min Speed Destage Delay (27-27).

### 1.7.10 Fixed speed only operation

Fixed Speed only operation is a feature designed to keep critical systems operating in the rare event that all of the variable speed pumps are unavailable to the cascade controller. In this situation the cascade controller will attempt to maintain system pressure by turning on and off fixed speed pumps.

**Staging:**

If all the variable speed pumps are unavailable and the system pressure goes below the Fixed Speed Only Operating Range (27-22) for the Staging Delay (27-23) time, then a fixed speed pump will be turned on. This repeats until all of the pumps are on.

**De-staging:**

If all of the variable speed pumps are unavailable and the system pressure goes above the Fixed Speed Only Operating Range (27-22) for the Destage Delay (27-24) time, a fixed speed pump will be turned off. This repeats until all of the pumps are off.



## 1.8 Cascade Controller Parameters

### 5-01 Terminal 27 Mode

Option:	Function:
[0] * Input	Defines terminal 27 as a digital input.
[1] Output	Defines terminal 27 as a digital output.

Please note that this parameter cannot be adjusted while the motor is running.

### 5-30 Terminal 27 Digital Output

Option:	Function:
	Same options and functions as par. 5-3*.

[0] * No operation	
--------------------	--

### Range:

Range:	Function:
100.000* [-999999.999 - 999999.999]	Enter the high reference value [RPM] for the motor shaft speed and the high feedback value, see also par. E-68 <i>Term. 33 High Ref./Feedb. Value.</i>

### 1.8.1 Cascade CTL Option, 27-\*\*

Cascade Control Option parameter group.

### 1.8.2 Control & Status, 27-0\*

Control and status parameters are for monitoring and manual control of the pumps.

Use Right [➡] and Left [⬅] arrow keys to choose pump. Use Up [▲] and

Down [▼] arrow keys to change settings.

### 27-01 Pump Status

Option:	Function:
	Pump Status is a readout parameter showing the status of each pump in the system. Possible settings are:
[0] Ready	the pump is available for use by the cascade controller.
[1] On Drive	the pump is controlled by the cascade controller, and the pump is connected to a drive, and is running.
[2] On Mains	the pump is controlled by the cascade controller, and the pump is connected to mains, and is running.
[3] Offline-Off	the pump is not available for use by the cascade controller, and the pump is off.
[4] Offline-On Mains	the pump is not available for use by the cascade controller, and the pump is connected to mains and is running
[5] Offline-On Drive	the pump is not available for use by the cascade controller, and the pump is connected to mains and is running
[6] Offline-Fault	the pump is not available for use by the cascade controller, and the pump is connected to mains and is running
[7] Offline-Hand	the pump is not available for use by the cascade controller, and the pump is connected to mains and is running
[8] Offline-External Interlock	the pump has been externally interlocked and is off.
[9] Spinning	the cascade control is executing a spin cycle for the pump.

[10] No Relay Connection the pump is not directly connected to a drive, and no relay has been assigned to the pump

### 27-02 Manual Pump Control

**Option:** **Function:**  
 Manual Pump Control is a command parameter that allows manual control of individual pump states. Selecting one of these will execute the command and then return to No Operation. Possible selections are:

[0] *	No Operation	Does nothing.
[1]	Online	Makes the pump available to the cascade controller.
[2]	Alternate On	Forces the selected pump to be the lead pump.
[3]	Offline-Off	Turns the pump off and makes the pump unavailable for cascading.
[4]	Offline-On	Turns the pump on and makes the pump unavailable for cascading.
[5]	Offline-Spin	Initiates a pump spin.

### 27-03 Current Runtime Hours

**Option:** **Function:**  
 Units: hrs  
 Current Runtime Hours is a readout parameter showing the total number of hours each pump has been running since last reset. This time is used to balance the running hours between pumps. The times may all be reset to 0 using parameter 27-91.

### 27-04 Pump Total Lifetime Hours

**Range:** **Function:**  
 0\* [0 - 2147483647]  
 Pump Total Lifetime Hours is the total operating hours for each connected pump. This parameter may be individually set to any value for maintenance purposes.

## 1.8.3 Configuration, 27-1\*

This parameter group is for configuring the cascade controller option.

### 27-10 Cascade Controller

**Option:** **Function:**  
 Cascade Controller Mode sets the operating mode. Possible selections are:

Disabled	Turns off cascade controller option.
Master/Follower	Operates using only variable speed pumps connected to Drives. This selection simplifies the setup.
Mixed Pumps	Operates using both variable and fixed speed pumps.
Basic Cascade Ctrl	Turns off the cascade option and reverts to basic cascade operation (See parameter group 25-** in the <i>VLT AQUA Drive Programming Guide</i> for further information). The additional relays on the option can be used to extend the Basic Cascade with 3 relays. Only Basic Cascade functions are available.

### 27-11 Number of Drives

**Range:** **Function:**  
 1\* [1 - 8]  
 Number of frequency converters to be controlled by the cascade controller.  
 MCO 101: 1-6  
 MCO 102: 1-8

### 27-12 No. of Pumps

**Range:** **Function:**  
 0\* [0 - No. of Drives]  
 Number of Pumps to be controlled by the cascade controller.  
 MCO 101: 0-6  
 MCO 102: 0-8

**27-14 Pump Capacity**

**Range:**

100%\* [0%(Off) - 800%]

**Function:**

Pump Capacity sets the capacity of each pump in the system relative to the first pump. This is an indexed parameter with one entry per pump. The capacity of the first pump is always considered to be 100%.

**27-16 Runtime Balancing**

**Option:**

**Function:**

Runtime Balancing sets the priority of each pump for balancing it's running hours. The pumps with the highest priority will be operated before the lower prioritised pumps. If all pumps are set as spare pump they will be staged and de-staged as no priority is set. It means staged in the order of 1-2-3 and de-staged as 3-2-1.

Possible selections are:

[0] *	Balanced Priority 1	Turned on first, turned off last.
[1]	Balanced Priority 2	Turned on if no priority 1 pumps are available. Turned off before priority 1 pumps are turned off.
[2]	Spare Pump	Turned on last, turned off first.

**27-17 Motor Starters**

**Option:**

**Function:**

Motor Starters selects the type of mains starters used on the fixed speed pumps. All of the fixed speed pumps must be configured the same. Possible choices are:

[0] *	Direct Online	
[1]	Soft starters	Adds a delay when staging and de-staging corresponding to the soft-starter ramp time, see par. 27-41 and par. 27-42.
[2]	Star-delta starters	Adds a delay at staging, controlled by par. 27-42.

**27-18 Spin Time for Unused Pumps**

**Range:**

0 sec\* [0 - 99 sec]

**Function:**

Spin Time for Unused Pumps sets the length of time to spin unused pumps. If a fixed speed pump has not been run in the last 72 hours, it will be turned on for this time. This is to prevent damage caused by leaving the pump off too long. The spin feature may be disabled by setting the value of this parameter to 0. Warning - Setting this parameter too large may over pressure some systems.

**27-19 Reset Current Runtime Hours**

**Option:**

**Function:**

Reset Current Runtime Hours is used to reset all of the Current Runtime Hours to zero. This time is used for runtime balancing.

[0] *	Do not reset
[1]	Reset

**1.8.4 Bandwidth Settings, 27-2\***

Parameters for configuring control response.

**27-20 Normal Operating Range**

**Range:**

10%\* [1% – P27-21]

**Function:**

Normal Operating Range is the allowed offset from the set-point before a pump may be added or removed. The system must be outside this limit for the time specified in P27-23 (Staging) or P27-24 (De-staging) before a cascade operation takes place. Normal refers to the system operating with at least one variable speed pump available. This value is entered as a % of Max Reference (See P21-12 in the *VLT AQUA Drive Programming Guide* for further information).

1

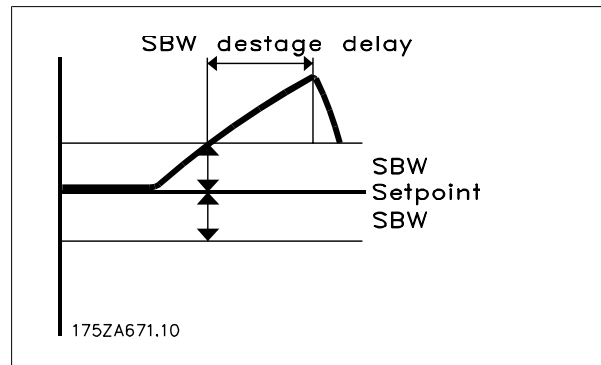
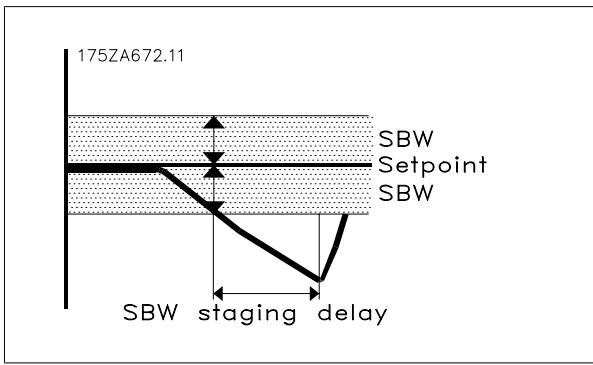

**27-21 Override Limit**

**Range:**

100% (Dis- [P27-20 - 100%]  
abled)\*

**Function:**

Override Limit is the allowed offset from the set-point before a pump will immediately be added or removed (for instance in case of a fire tab is switched on). Normal Operating Range includes a delay that limits the system response to transients. This makes the system respond too slowly to large demand changes. The override limit causes the drive to respond immediately. The value is entered as a % of Max Reference (P21-12). Override operation may be disabled by setting this parameter to 100%.

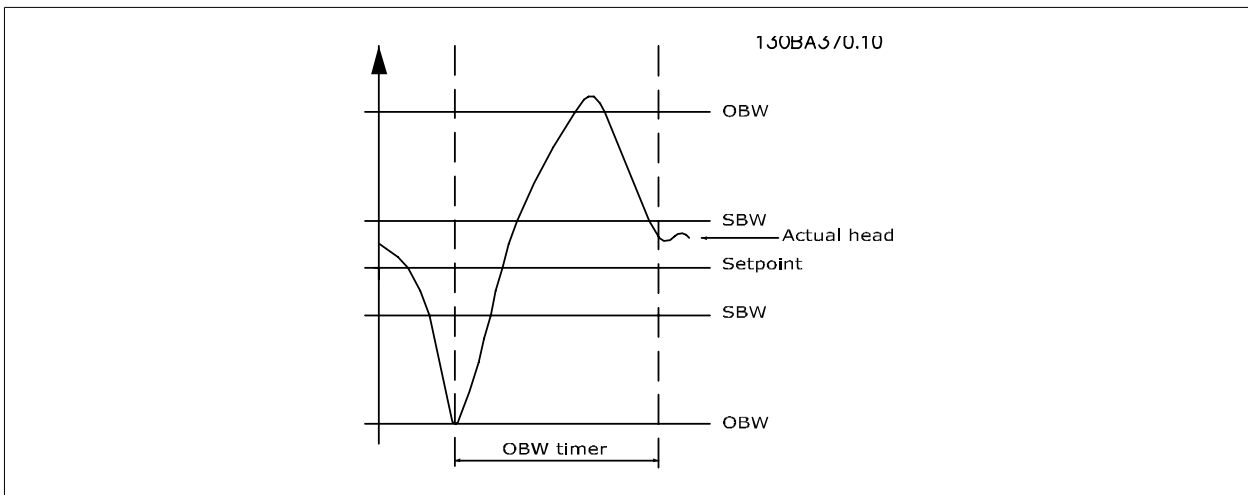

**27-22 Fixed Speed Only Operating Range**

**Range:**

P27-20\* [P27-20 - P27-21]

**Function:**

Fixed Speed Only Operating Range is the allowed offset from the set-point before a pump may be added or removed when there are no operational variable speed pumps. The system must be outside this limit for the time specified in P27-23 (Staging Delay) or P27-24 (De-staging Delay) before a cascade operation may take place. The value is entered as a % of Max Reference. When there are no operational variable speed pumps, the system will try to maintain control with the remaining fixed speed pumps.

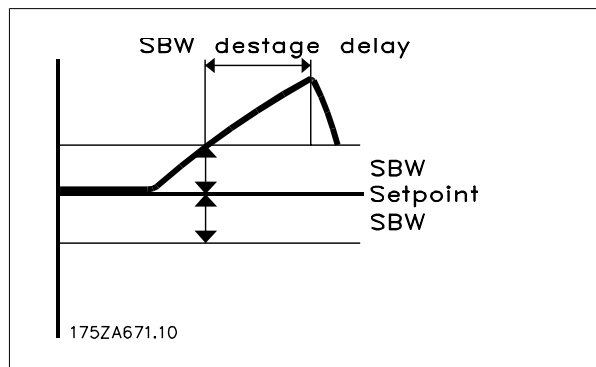
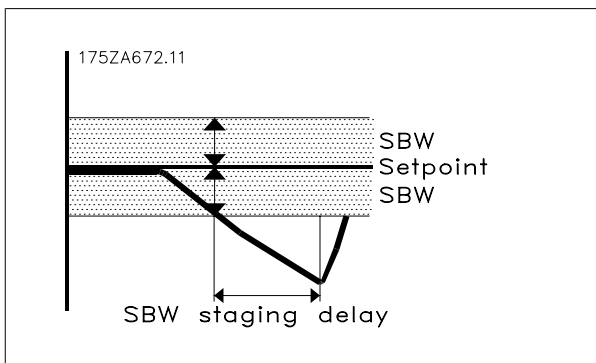

**27-23 Staging Delay**

**Range:**

15 s\* [0 - 3000 s]

**Function:**

Staging Delay is the time that the system feedback must remain below the operating range before a pump may be turned on. If the system is operating with at least one variable speed pump available, the Normal Operating Range (P27-20) is used. If there are no variable speed pumps available, the Fixed Speed Only Operating Range (P27-22) is used.

**27-24 Destaging Delay**

**Range:**

15 s\* [0 - 3000 s]

**Function:**

De-staging Delay is the time that the system feedback must remain above the operating range before a pump may be turned off. If the system is operating with at least one variable speed pump available, the Normal Operating Range (P27-20) is used. If there are no variable speed pumps available, the Fixed Speed Only Operating Range (P27-22) is used.

**27-25 Override Hold Time**

**Range:**

10 s\* [0 - 300 s]

**Function:**

Override Hold Time is the minimum time that must elapse after a stage or de-stage before a stage or de-stage may take place due to the system exceeding the Override Limit (P27-21). The override hold time is designed to allow the system to stabilize after a pump is turned on or off. If this delay is not long enough, the transients caused by turning a pump on or off may cause the system to add or remove another pump when it should not.

**27-27 Min-Speed De-stage Delay**

**Range:**

15 s\* [0 - 300 s]

**Function:**

Min-Speed De-stage Delay is the time that the lead pump must be running at minimum speed while the system feedback is still inside the normal operating band before a pump will be turned off to save energy. Energy savings may be realized by turning off a pump if the variable speed pumps are operating at minimum speed but the feedback is still in band. Under these conditions, a pump may be turned off and the system will still be able to maintain control. The pumps that remain on will then be operating more efficiently.

1

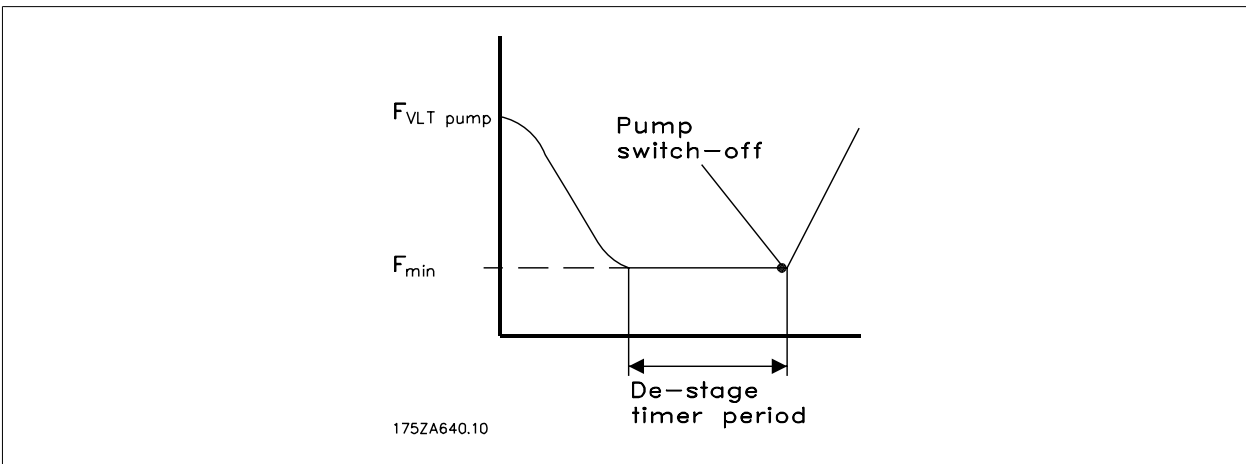

### 1.8.5 Staging Speed, 27-3\*

Parameters for configuring Master/Follower control response.

#### 27-30 Auto Tune Staging Speeds

**Option:**

**Function:**

When enabled the stage on and off speeds will continually be auto tuned during operation. The settings will be optimized in order to ensure a high performance and low energy consumption.

[0] Disabled

[1] \* Enabled

When par. 27-30 is Enabled [1], par. 27-31, par. 27-32, par. 27-33, and par. 27-34 will be kept up to date with new automatically calculated values. If par. 27-31, par. 27-32, par. 27-33, and par. 27-34 are modified from the bus or LCP, then the new values will be used but will continue to be automatically tuned.

Values will be recalculated and the parameters updated when staging occurs.

#### 27-31 Stage On Speed (RPM)

**Range:**

P4-13\* [par. 4-11 – par. 4-13]

**Function:**

To be used if RPM is chosen.

If the lead pump is operating above Stage On Speed for the time specified in Staging Delay (par. 27-23), and a variable speed pump is available, it will be turned on.

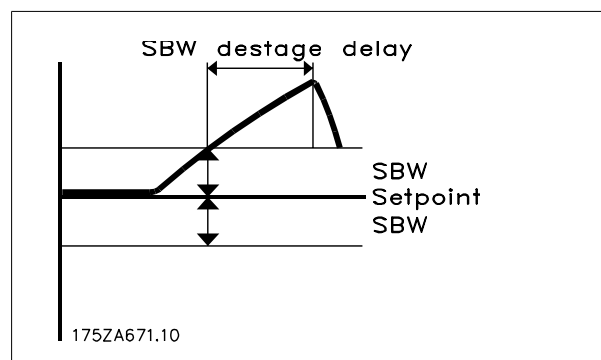
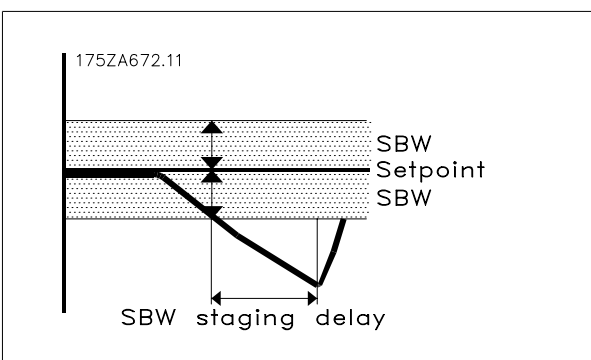

#### 27-32 Stage On Speed (Hz)

**Range:**

par. 4-14\* [par. 4-12 – par. 4-14]

**Function:**

To be used if Hz is chosen.

If the lead pump is operating above Stage On Speed for the time specified in Staging Delay (par. 27-23), and a variable speed pump is available, it will be turned on.

**27-33 Stage Off Speed (RPM)**

**Range:**  
par. 4-11\* [par. 4-11 – par. 4-13]

**Function:**  
If the lead pump is operating below Stage Off Speed for the time specified in De-staging Delay (par. 27-24), and more than one variable speed pump is on, a variable speed pump will be turned off.

**27-34 Stage Off Speed (Hz)**

**Range:**  
par. 4-12\* [par. 4-12 – par. 4-14]

**Function:**  
If the lead pump is operating below Stage Off Speed for the time specified in De-staging Delay (par. 27-24), and more than one variable speed pump is on, a variable speed pump will be turned off.

**1.8.6 Staging Settings, 27-4\***

Parameters for configuring staging transitions.

**27-40 Auto Tune Staging Settings**

**Option:** **Function:**  
When enabled the staging and de-staging threshold will be auto tuned during operation. The settings will be optimized in order to prevent pressure over and undershoots when staging and de-staging.

[0] *	Disabled	Staging or de-staging threshold.
[1]	Enabled	

**27-41 Ramp Down Delay**

**Range:** **Function:**  
10 s\* [0 – 120 s]  
Ramp Down Delay sets the delay between turning on a soft starter controlled pump and ramping down the drive controlled pump. This is only used for soft starter and star/delta controlled pumps.

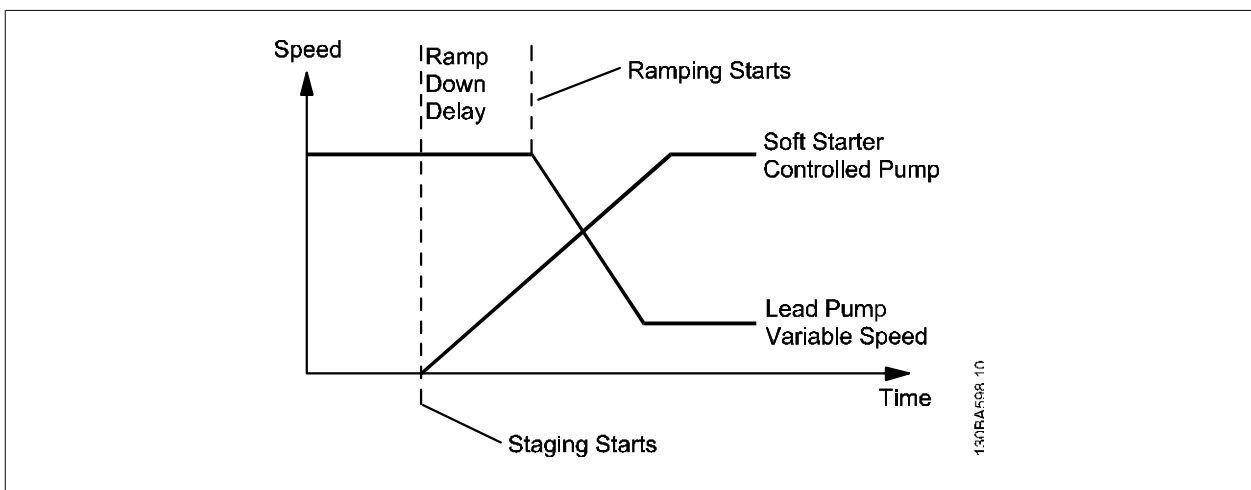

**NB!**  
Also used in star/delta pumps.

**27-42 Ramp Up Delay**

**Range:** **Function:**  
2 s\* [0 s – 12 s]  
Sets the delay between turning off a soft starter controlled pump and ramping up the drive controlled pump. This is only used for soft starter controlled pumps.

1

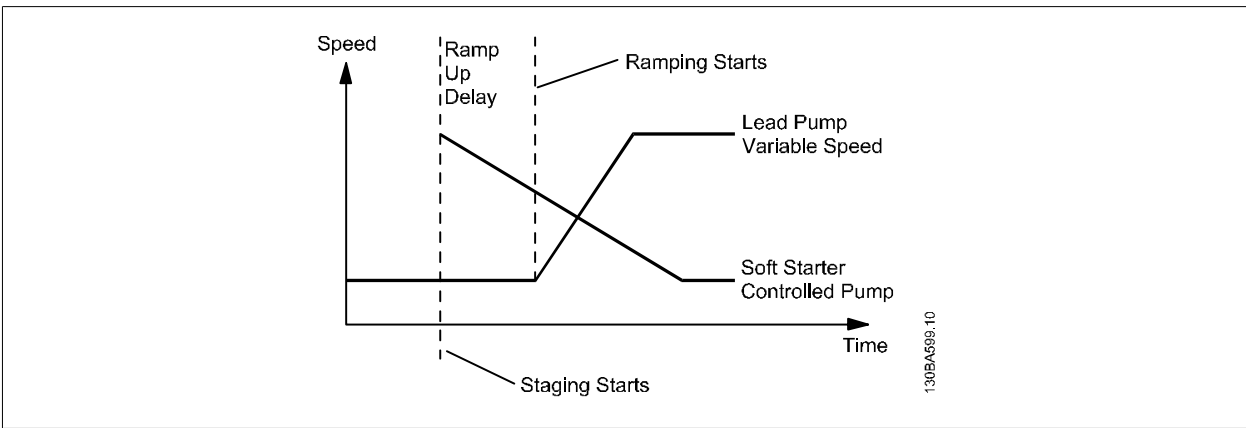

**NB!**

Not used with star/delta controlled pumps.

**27-43 Staging Threshold**

**Range:**

90%\* [1 – 100%]

**Function:**

Staging Threshold is the speed in the staging ramp at which the fixed speed pump should be turned on. Set as a percentage [%] of maximum pump speed. When 27-40 is Enabled [1], 27-43, and 27-44 will be kept up to date with new automatically calculated values. If 27-43, and 27-44 are modified from the bus or LCP, then the new values will be used, but will continue to be automatically tuned.

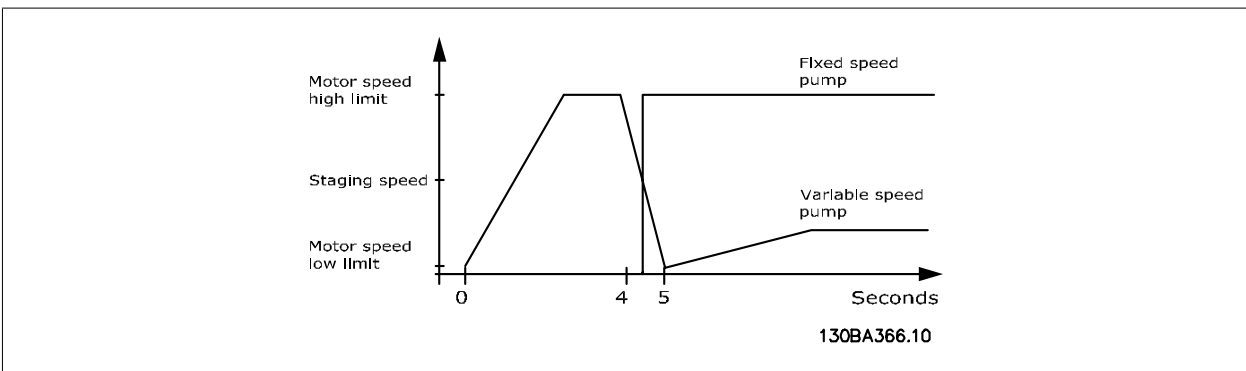

**27-44 De-staging Threshold**

**Range:**

50%\* [1 – 100%]

**Function:**

De-staging Threshold is the speed in the staging ramp at which the fixed speed pump should be turned on. Set as a percentage [%] of maximum pump speed. When 27-40 is Enabled [1], 27-43, and 27-44 will be kept up to date with new automatically calculated values. If 27-43, and 27-44 are modified from the bus or LCP, then the new values will be used, but will continue to be automatically tuned.



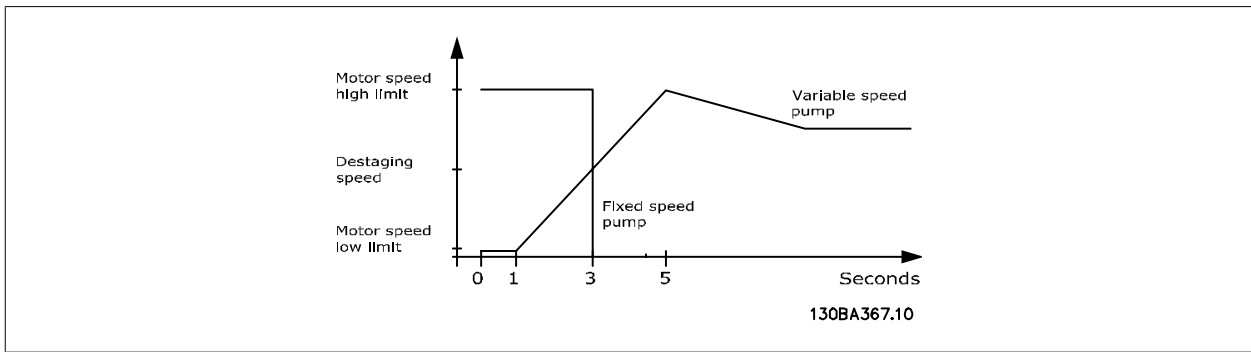

**27-45 Staging Speed (RPM)**

**Option:** Units: RPM  
**Function:** Staging Speed is a readout parameter that shows the actual staging speed based on the staging threshold.

**27-46 Staging Speed (Hz)**

**Option:** Units: Hz  
**Function:** Staging Speed is a readout parameter that shows the actual staging speed based on the staging threshold.

**27-47 De-staging Speed (RPM)**

**Option:** Units: RPM  
**Function:** De-staging Speed is a readout parameter that shows the actual de-staging speed based on the de-staging threshold.

**27-48 Destaging Speed (Hz)**

**Option:** Units: RPM  
**Function:** Destaging Speed is a readout parameter that shows the actual destaging speed based on the de-staging threshold.

**1.8.7 Alternation Settings, 27-5\***

Parameters for configuring alternations.

**27-51 Alternation Event**

**Option:**  
**Function:** Alternation Event allows alternation at destage.

- [0] \* Off
- [1] At Destage

**27-52 Alternation Time Interval**

**Range:** 0 (Disa- [0 (Disabled) – 10000 m] bled)\*  
**Function:** Alternation Time Interval is the user settable time between alternations. It is disabled by setting it to 0. Parameter 27-53 shows the time remaining until the next alternation occurs.

**27-53 Alternation Timer Value**

**Option:** Units: min  
**Function:** Alternation Timer Value is a readout parameter that shows the time remaining before an interval based alternation takes place. Parameter 27-52 sets the time interval

1

**27-54 Alternate at Time of Day**

**Option:** [0] \* Disabled  
 [1] Time of Day

**Function:** Alternate at Time of Day allows selecting a specific time of day for alternating pumps. The time is set in parameter 27-55. Alternation at Time of Day requires the real time clock to be set.

**27-55 Alternation Predefined Time**

**Range:** 1:00\* [00:00 – 23:59]

**Function:** Alternation Predefined Time is the time of day for pump alternation. This parameter is only available if parameter 27-54 is set to Time of Day.

**27-56 Alternate Capacity is <**

**Range:** 0% (Off)\* [0% (Off) – 100%]

**Function:** Alternate Capacity is < requires the lead pump to be operating below this capacity before time based alternation will be allowed to take place. This feature ensures that alternation only takes place when the pump is running below a speed where interruption in operation will not affect the process. This minimizes the system disturbance caused by alternations. The value is entered as a % of the capacity of pump 1. Alternate Capacity is < operation may be disabled by setting this parameter to 0%.

**27-58 Run Next Pump Delay**

**Range:** 0.1s\* [0.1s – 5s]

**Function:** Run Next Pump Delay is a delay between stopping the current lead pump and starting the next lead pump when alternating lead pumps. This provides time for the contactors to switch while both pumps are stopped.

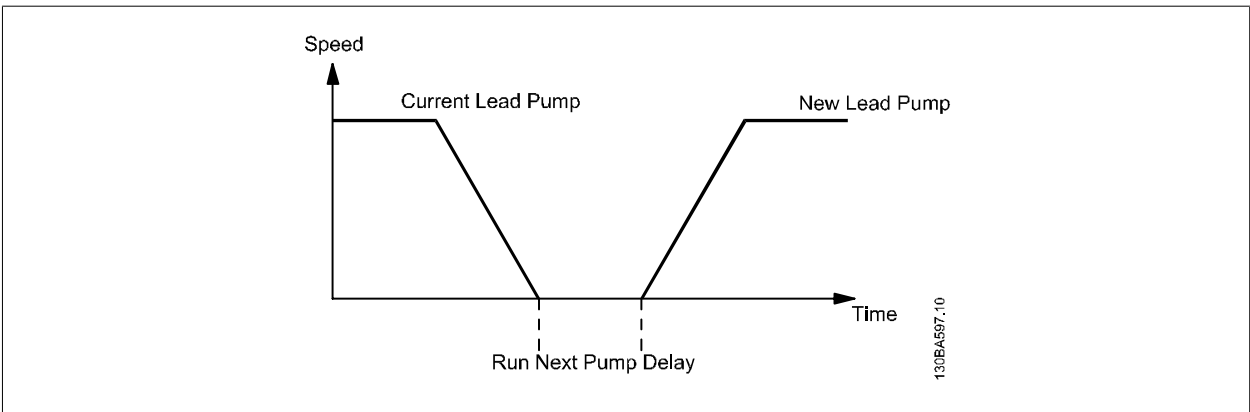

**1.8.8 Connections, 27-7\***

Parameters for configuring relay connections.

**27-70 Relay**

**Option:** Standard Relay

**Function:** P27-70 is an array parameter used to setup the function of the option relays. Depending on which option is installed only the available relays will be visible. If Extended Cascade controller is installed, relay 10-12 will be visible. If Advanced Cascade controller is installed relay 13-20 will be visible. In both cases, the standard relays (Relay1 and Relay2) will be accessible as well as the relays in the B-option MCB-105 (if that option is installed in combination with advanced cascade). To setup the function of each relay, choose the specific relays and then choose the function. If the function option: Standard Relay is chosen, the relay can be used as general purpose relay and the wanted function can then be setup in parameter P5-4\*.

[0]	Drive X Enable	Enable follower drive X
	Pump K to Drive N	Connect pump K to drive N
	Pump K to Mains	Connect pump K to mains



**NB!**  
If MCO 102 is installed, the relay option MCB 105 may also be available for cascade control.

### 1.8.9 Readouts, 27-9\*

Cascade Control Option Readout Parameters

#### 27-91 Cascade Reference

Cascade Reference is a readout parameter that shows the reference output for use with follower drives. This reference is available even when the master drive is stopped. This is the speed that the drive is operating at or would be operating at if it were on. It is scaled as a percent of *Motor Speed High Limit* (P4-13[RPM] or P4-14[Hz]).

Units: %

#### 27-92 Current % of Total Capacity

Current % of Total Capacity is a readout parameter that shows the system operating point as a % capacity of total system capacity. 100% means all pumps are on at full speed.

Units: %

#### 27-93 Cascade Option Status

**Option:**

**Function:**

Cascade Option Status is a readout parameter to show the status of the cascade system.

[0] *	Disabled	The cascade option is not used.
	Off	The cascade option is turned off.
	Running	The cascade option is running normally.
	Running at FSBW	The cascade option is running in fixed speed mode. No variable speed pumps are available.
	Jogging	The system is running at the jog speed set in P3-11.
	In Open Loop	The system is set to open loop.
	Frozen	The system is frozen in the current state. No changes will take place.
	Emergency	The system is stopped due to Coast, Safety Interlock, Trip Lock, or Safe Stop.
	Alarm	The system is operating with an alarm condition.
	Staging	A staging operation is in progress.
	Destaging	A destaging operation is in progress.
	Alternating	An alternation operation is in progress.
	Lead Pump Not Set	A lead pump has not been selected.

#### 27-94 Cascade System Status

Cascade System Status is a readout parameter that shows the status of each individual pump.

1

1.9.1 Parameter Lists - Group 27- \*\*

Par. No. #	Parameter description	Default value	4-set-up	Change during operation	Conversion index	Type
<b>27-0* Control &amp; Status</b>						
27-01	Pump Status	[0] Ready	All set-ups	TRUE	-	Uint8
27-02	Manual Pump Control	[0] No Operation	2 set-ups	TRUE	-	Uint8
27-03	Current Runtime Hours	0 h	All set-ups	TRUE	74	Uint32
27-04	Pump Total Lifetime Hours	0 h	All set-ups	TRUE	74	Uint32
<b>27-1* Configuration</b>						
27-10	Cascade Controller	[0] Disabled	2 set-ups	FALSE	-	Uint8
27-11	Number Of Drives	1 N/A	2 set-ups	FALSE	0	Uint8
27-12	Number Of Pumps	SR	2 set-ups	FALSE	0	Uint8
27-14	Pump Capacity	100 %	2 set-ups	FALSE	0	Uint16
27-16	Runtime Balancing	[0] Balanced Priority 1	2 set-ups	TRUE	-	Uint8
27-17	Motor Starters	[0] Direct Online	2 set-ups	FALSE	-	Uint8
27-18	Spin Time for Unused Pumps	SR	All set-ups	TRUE	0	Uint16
27-19	Reset Current Runtime Hours	[0] Do not reset	All set-ups	TRUE	-	Uint8
<b>27-2* Bandwidth Settings</b>						
27-20	Normal Operating Range	SR	All set-ups	TRUE	0	Uint8
27-21	Override Limit	100 %	All set-ups	TRUE	0	Uint8
27-22	Fixed Speed Only Operating Range	SR	All set-ups	TRUE	0	Uint8
27-23	Staging Delay	15 s	All set-ups	TRUE	0	Uint16
27-24	Destaging Delay	15 s	All set-ups	TRUE	0	Uint16
27-25	Override Hold Time	10 s	All set-ups	TRUE	0	Uint16
27-27	Min Speed Destage Delay	SR	All set-ups	TRUE	0	Uint16
<b>27-3* Staging Speed</b>						
27-30	Auto Tune Staging Speeds	[1] Enabled	All set-ups	TRUE	-	Uint8
27-31	Stage On Speed [RPM]	SR	All set-ups	TRUE	67	Uint16
27-32	Stage On Speed [Hz]	SR	All set-ups	TRUE	-1	Uint16
27-33	Stage Off Speed [RPM]	SR	All set-ups	TRUE	67	Uint16
27-34	Stage Off Speed [Hz]	SR	All set-ups	TRUE	-1	Uint16
<b>27-4* Staging Settings</b>						
27-40	Auto Tune Staging Settings	[0] Disabled	All set-ups	TRUE	-	Uint8
27-41	Ramp Down Delay	10.0 s	All set-ups	TRUE	-1	Uint16
27-42	Ramp Up Delay	2.0 s	All set-ups	TRUE	-1	Uint16
27-43	Staging Threshold	SR	All set-ups	TRUE	0	Uint8
27-44	Destaging Threshold	SR	All set-ups	TRUE	0	Uint8
27-45	Staging Speed [RPM]	0 RPM	All set-ups	TRUE	67	Uint16
27-46	Staging Speed [Hz]	0.0 Hz	All set-ups	TRUE	-1	Uint16
27-47	Destaging Speed [RPM]	0 RPM	All set-ups	TRUE	67	Uint16
27-48	Destaging Speed [Hz]	0.0 Hz	All set-ups	TRUE	-1	Uint16

Par. No. #	Parameter description	Default value	4-set-up	Change during operation	Conversion index	Type
<b>27-5* Alternate Settings</b>						
27-50	Automatic Alternation	[0] Disabled	All set-ups	FALSE	-	Uint8
27-51	Alternation Event	null	All set-ups	TRUE	-	Uint8
27-52	Alternation Time Interval	0 min	All set-ups	TRUE	70	Uint16
27-53	Alternation Timer Value	0 min	All set-ups	TRUE	70	Uint16
27-54	Alternation At Time of Day	[0] Disabled	All set-ups	TRUE	-	Uint8
27-55	Alternation Predefined Time	SR	All set-ups	TRUE	0	TimeOfDayWobDate
27-56	Alternate Capacity is <	0 %	All set-ups	TRUE	0	Uint8
27-58	Run Next Pump Delay	0.1 s	All set-ups	TRUE	-1	Uint16
<b>27-6* Digital Inputs</b>						
27-60	Terminal X66/1 Digital Input	[0] No operation	All set-ups	TRUE	-	Uint8
27-61	Terminal X66/3 Digital Input	[0] No operation	All set-ups	TRUE	-	Uint8
27-62	Terminal X66/5 Digital Input	[0] No operation	All set-ups	TRUE	-	Uint8
27-63	Terminal X66/7 Digital Input	[0] No operation	All set-ups	TRUE	-	Uint8
27-64	Terminal X66/9 Digital Input	[0] No operation	All set-ups	TRUE	-	Uint8
27-65	Terminal X66/11 Digital Input	[0] No operation	All set-ups	TRUE	-	Uint8
27-66	Terminal X66/13 Digital Input	[0] No operation	All set-ups	TRUE	-	Uint8
<b>27-7* Connections</b>						
27-70	Relay	[0] Standard Relay	2 set-ups	FALSE	-	Uint8
<b>27-9* Readouts</b>						
27-91	Cascade Reference	0.0 %	All set-ups	TRUE	-1	Int16
27-92	% Of Total Capacity	0 %	All set-ups	TRUE	0	Uint16
27-93	Cascade Option Status	[0] Disabled	All set-ups	TRUE	-	Uint8
27-94	Cascade System Status	0 N/A	All set-ups	TRUE	0	VisStr[25]

# 1 1.10 Master/Follower Application Note

## Application Description

The system used as example contains 4 equal sized pumps in a water distribution system. They are each connected to a Danfoss VLT® AQUA Drive. A pressure transmitter with an analogue output format of 4-20mA is used as feedback and connected to the drive named the 'master drive'. The master drive also includes the Danfoss *VLT® Extended Cascade Controller Option MCO-101*. The purpose of the system is to maintain a constant pressure in the system.

Arguments for using a 'master / follower' setup instead of the standard cascade control mode could be:

- In old and weak pipe system where huge pressure surges can lead to leakage, the high performance of the master / follower mode can be a real benefit.
- In constant pressure water systems the pumps can be operated in the most energy efficient way by using Master / follower operation.
- In systems with large variances in flow, the fast reacting Master / Follower mode will safely and fast maintain a constant pressure.
- Very easy installation - no need for external equipment. The drives can be delivered in IP55 or even IP66, which means no need for panels, except for fuses.

## Issues to keep in mind

Compared to traditional cascade control the number of running pumps is controlled by speed instead of feedback. To obtain the highest energy saving the stage on and off speed must be set correctly according to the system. To understand the principle better, please note figure 1.

The stage on and off speed is set by the user for each stage. The right speed depends on the application and the system. In VLT® AQUA software version higher than 1.1, the speed will be auto-tuned by the drive. The right settings can also be determined by using the Danfoss PC software called MUSEC, which is downloadable from our homepage: [www.danfoss.com](http://www.danfoss.com)

For a start the settings showed in table 1.1 can be used in most applications.

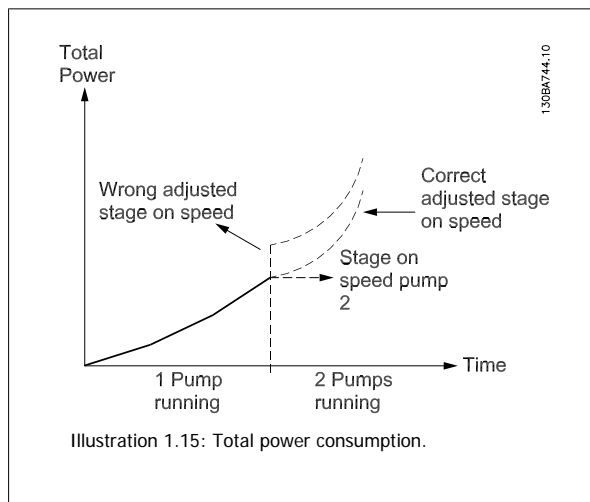

Stages	Stage on speed [Hz] (Par. 27-32)	Stage off speed [Hz] (Par. 27-34)
Stage 1	40	Min. speed
Stage 2	44	38
Stage 3	46	40
Stage 4	48	42

Table 1.2: Example of stage on and stage off speed

**Electrical wiring**

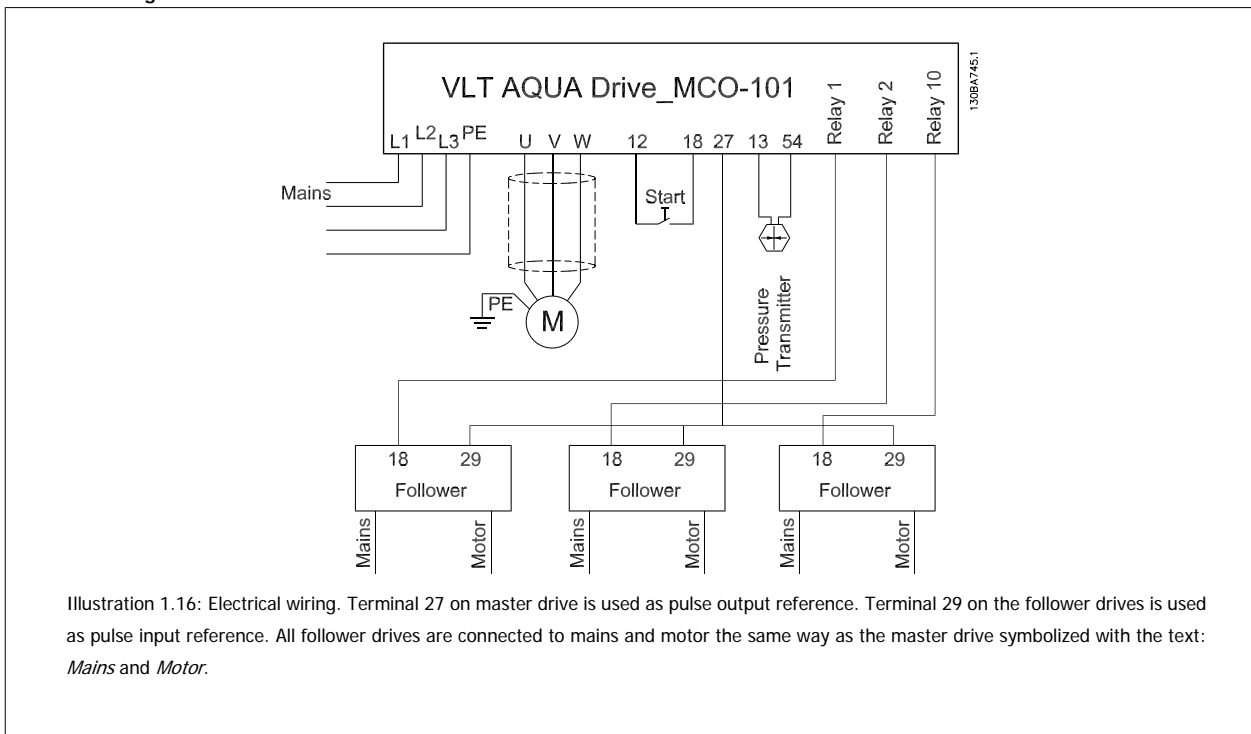

**NB!**  
In the example it is assumed that the pressure transmitter used as feedback sensor, has a range from 0-10 bar.

**Parameter settings:**

Display settings - Master drive:		
Display Line 1.1 Small	0-20	Reference [1601]
Display Line 1.2 Small	0-21	Feedback [1652]
Display Line 1.3 Small	0-22	Motor current [1614]
Display Line 2 Large	0-23	Frequency [1613]
Display Line 3 Large	0-24	Cascade reference [2791]

Display settings - Follower drives:		
Display Line 1.1 Small	0-20	External Reference [1650]
Display Line 3 Large	0-24	Frequency [1613]

 **NB!**  
Please note: the format of the analogue input is set using switch S201 below the LCP.

**Basic settings for both Master and Follower drives:**

1

Parameter:	No:	Comment:
Change from RPM to Hz as speed unit	0-02	
Motor rated power	1-20 / 1-21	(kW / HP)
Motor rated voltage	1-22	
Motor Current	1-24	
Motor Rated Speed	1-25	
Motor Rotation Check	1-28	Check rotation direction
Enable Automatic Motor Adaptation	1-29	
Ramp Up Time	3-41	(5 sec.* Depending on size) Must be the same in Master and Follower!
Ramp Down Time	3-42	(5 sec.* Depending on size) Must be the same in Master and Follower!
Motor Speed Low Limit [Hz]	4-12	(30 Hz)
Motor Speed High Limit [Hz]	4-14	(50 Hz) Must be the same in Master and Follower!

**Settings for the Master drive only**

1. Use the *Closed Loop Wizard* under *Quick Menu\_Function Setup*, to easily set up the feedback settings and the PID controller.
2. Set up the master configuration in par. 27-\*\*

Parameter:	No:	Comment
Configuration mode	27-10	Master/Follower
Set number of drives	27-11	4
Set the staging speed according to table 1.1	27-3*	
Configure Relay 1	27-70	Drive 2 Enable
Configure Relay 2	27-70	Drive 3 Enable
Configure Relay 10	27-70	Drive 4 Enable
Minimum Reference	3-02	0 [bar]
Maximum Reference	3-03	10 [bar]
Terminal 27 Mode	5-01	Output [1]
Terminal 27 Digital Output	5-30	Pulse output [55]
Terminal 27 Pulse Output Variable	5-60	Cascade Reference [116]
Pulse Output Maximum Frequency #27	5-62	5000 [Hz]

**Settings for the Follower drives only**

Set Reference 1 Source	3-15	Pulse input 29 [7]
Set Terminal 29 Digital Input	5-13	Pulse input [32]
Set Term. 29 Low Frequency	5-50	0 [Hz]
Set Term. 29 high frequency	5-51	5000 [Hz]

**Autotuned Stage on/off Speeds**

If stage on/off autotune is enabled in P27-30, the speed in table 1.1 will be auto optimised during operation and ensure optimised performance.

**Operation**

When the system is set to operation, the master drive will automatically run *time balance* with all drives running with the needed number of pumps depending on the demand. If, for some reason the user wants to prioritize which motors should be preferred, it is possible to prioritize the pumps in par. 27-16 in three levels. (Priority 1, Priority 2 and spare pump). Pumps with priority 2 will only be staged on when there is no priority 1 pump available. It might be necessary to fine adjust the *stage on/off* speed to optimise the energy consumption, if not auto tuned.



## Index

### A

Additional Configuration For Multiple Drives	19
Analogue Input	39
Analogue Output Format Of 4-20ma	38
Auto Tune Staging Settings, 27-40	31
Auto Tune Staging Speeds, 27-30 (to Be Included In Future Versions!)	30

### B

Bandwidth Settings, 27-2*	27
Basic Cascade Controller	6
Basic Settings	39

### C

Cascade Controller Features	21
Cascade Controller Option	6
Cascade Controller, 27-10	26
Cascade Ctl Option, 27-**	25
Caution	5
Closed Loop Control	20
Configuration, 27-1*	26
Configuring The System	18
Constant Pressure	38
Constant Pressure Water Systems	38
Control & Status, 27-0*	25
Critical Systems	24
Current Runtime Hours, 27-03	26

### D

De-staging	20, 24
De-staging Delay, 27-24	29
De-staging Speed (rpm), 27-47	33
De-staging Threshold, 27-44	32
Display Settings - Follower Drives	39
Display Settings - Master Drive	39
Drive Configurations	10

### E

Earth Leakage Current	3
Easy Installation	38
Electrical Wiring	39
Energy Saving	38
Extension Of Basic Cascade - Parameter Group 25** Control Mode	11

### F

Feedback Pressure	14, 23
Feedback Sensor	20, 39
Fixed Speed	24
Fixed Speed Only Operating Range, 27-22	28
Fixed Speed Pump	6
Fixed Speed Pump Configuration	12
Fixed Speed Pump Configuration	12
Follower Drive	6
Follower Drives	19
Free Software	20

### I

Introduction	10
Introduction To Mco 101 And Mco 102	5
Ip55 Or Even Ip66	38

## L

Lead Pump	23, 24
Lifetime Hours	23

## M

Manual Pump Control	22
Manual Pump Control, 27-02	26
Master Drive	38
Master Drive	6, 19
Master/follower Operation	38
Master-follower Configuration	13
Min-speed De-stage Delay, 27-27	29
Mixed Pump Configuration	14, 17
Mixed Pump Selection	19
Motor Starters, 27-17	27
Multiple Drives	23
Multiple Unit Staging Efficiency Calculator	20
Musec	20, 38

## N

Normal Operating Range, 27-20	27
Number Of Drives	19
Number Of Drives, 27-11	26
Number Of Pumps, 27-12	26

## O

Open Loop Mode	6
Optimise The Energy Consumption	40
Override Hold Time, 27-25	29
Override Limit	24, 28
Override Limit, 27-21	28
Override Staging /destaging	24

## P

Parameter Lists -	36
Parameter Settings	39
Pid Controller	20
Pressure Fluctuations	12
Pressure Transmitter	39
Prioritize The Pumps	40
Pump Capacity	19
Pump Capacity, 27-14	26
Pump Spin	23
Pump Status, 27-01	25
Pump Total Lifetime Hours, 27-04	26

## R

Ramp Down Delay, 27-41	31
Ramp Up Delay, 27-42	31
Relay, 27-70	34
Reset Current Runtime Hours, 27-19	27
Runtime Balancing	17, 19, 22
Runtime Balancing, 27-16	27

## S

Settings For The Follower Drives	40
Settings For The Master Drive	40
Setting-up The Cascade Parameters	18
Single Drive	23
Soft Starters	18
Software Version	38
Software Version	3

Speed Instead Of Feedback .....	38
Spin Time .....	23, 27
Spin Time For Unused Pumps .....	19
Stage Off Speed (hz), 27-34 .....	31
Stage Off Speed (rpm), 27-33 .....	30
[Stage Off Speed Hz] .....	38
Stage On And Off Speed .....	38
Stage On And Stage Off .....	38
Stage On Speed (hz), 27-32 .....	30
Stage On Speed (rpm), 27-31 .....	30
[Stage On Speed Hz] .....	38
Staging .....	20, 24
Staging / Destaging .....	23
Staging / De-staging Of Fixed Speed Pumps Based On Pressure Feedback .....	21
Staging / De-staging Of Variable Speed Pumps Based On Drive Speed .....	20
Staging And De-staging Decisions .....	13
Staging Delay, 27-23 .....	29
Staging Settings, 27-4* .....	31
Staging Speed (hz), 27-46 .....	33
Staging Speed (rpm), 27-45 .....	33
Staging Speed, 27-3* .....	30
Staging Threshold, 27-43 .....	32
Supported Configurations .....	10
Switch S201 .....	39

## T

Terminal 27 .....	39
Terminal 27 Mode 5-01 .....	25
Terminal 29 .....	39

## U

Unequal Size Pump Configuration .....	15
---------------------------------------	----

## V

Variable Speed Pumps .....	6
Vlt® Extended Cascade Controller Option Mco-101 .....	38

## W

Weak Pipe System .....	38
------------------------	----